

RUN10/15

RUN10P/15P

RUN10T/15T

OPERATOR FOR PEDESTRIAN SLIDING DOORS
ELECTRICAL INSTALLATION GUIDE

www.erreka.com

General safety instructions 4

Symbols used in this guide _____	6
Importance of this guide _____	6
Envisaged use _____	6
Installer's qualifications _____	6
Operator safety elements _____	6
Dangers in the closing edges _____	6
Manual review _____	6



Description of the product 7

Pre-installation and complete installation elements _____	7
Characteristics of operators RUN10/15 and RUN10P/15P _____	8
Characteristics of operators RUN10T / RUN15T _____	9



Operator operation 10

Operation modes _____	10
Digital selector (DIG SELN1) _____	11
Rotary Selector (ROT SELN1) _____	11

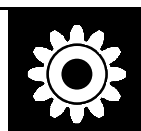

Electrical installation 12

Electronic board _____	12
Connecting components and peripherals _____	13



Installation - Door Configuration 32

Setup _____	32
Regulating parameters _____	33
User menu _____	35
Setup menu _____	36
Warnings / Errors _____	41

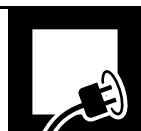

Annexes 44

Maintenance _____	44
Warranty _____	44



WARNINGS



The device may be used by children aged 8 and over and by persons with reduced physical, sensory or mental abilities, or a lack of experience and knowledge, whenever they have adequate supervision or training.

Children must not be allowed to play with the device.

The device must not be cleaned or maintained by children unless supervised.

A means of disconnection must be fitted for the fixed installation, with a contact separation in all poles that allows complete disconnection under overvoltage category III, in accordance with installation regulations. Its specific characteristics (rated current, voltage, etc.) must be suitable for the installation and the elements used.

The device must be attached to its support, as described in the "Fastening the elements" section of this guide.

The device's trade name is shown on the cover of this guide. The manufacturer's full address is shown on the back cover of this guide.

The operator type or model reference is shown in the "Operator characteristics" section of this guide.

Proper use of the device is set out under "Intended use". Any use other than that described in the guide is considered improper and forbidden, as it could result in injury and damage to property.

The name of the device is shown in the "Operator characteristics" section of this guide.

WARNING: Important safety instructions. These instructions must be followed in order to guarantee the safety of people. Keep these instructions in a safe place.

WARNING: The device should be disconnected from its power source during cleaning and maintenance, and when replacing parts.

Do not allow children to play with the device or its controls, including remote controls.

The explanation of the mode indicators can be found in the section "Types of door and normal operating modes" of this guide.

Details on how to use any manual release device, or a reversible operator used as a manual release device, are shown in the instructions manual for the operator in question.

The user must NOT readjust the controls; this must be left to a qualified professional.

Regularly inspect the facility for any imbalance or signs of wear or deterioration of the cables or the assembly. Do not use the device if any repairs or adjustments are required.

The A-weighted emission sound pressure level of the device is equal to or less than 80 dB(A):
 $L_{pA} \leq 80 \text{ dB(A)}$.

WARNINGS FOR INSTALLATION

WARNING: Important safety instructions. Follow all instructions, as improper installation can result in serious injury.

The device weighs less than 30 kg, meaning handling equipment is not required.

The required installation components are shown in the "Elements of the complete installation" section. Details and instructions for all the components can be found at the website www.erreka.com.

Before installing the device, check that the actuated part is in good mechanical condition, that it is correctly balanced, and that it opens and closes correctly.

None of the hazardous parts of the device are designed to be installed at more than 3 m above ground level or other access level.

Ensure that any trapping between the actuated part and the surrounding fixed parts due to the opening movement of the actuated part is avoided.

The details to install the device are shown in the "Installation" chapter of this guide. If protective devices not supplied with this device are installed, refer to the instructions for those components.

Details on how to regulate the controls are shown in the "Installation - Door configuration" section of this guide.

Once installed, ensure the mechanism is regulated correctly and the protection system and any manual release devices work properly.

The list of all components included in the device is shown in the "Unpacking and contents" section of this guide.

The specification of the type of door, gate or window the device is intended for, the size and mass of the actuated part or the mass of the actuated part and required torque are shown in the section "Operator characteristics".

The position or positions the device can be installed in can be seen in the "Normal operation modes" section of this guide.



WARNINGS FOR SCRAP

The product should be dismantled by qualified personnel at the end of its working life.

This product consists of a variety of materials, some of which can be recycled and others which must be disposed of. Users must be aware of the different recycling and disposal systems envisaged in local regulations.

Some parts of this product may contain contaminating or hazardous substances which, if released, could harm the environment and human health.



Discarding this device along with household waste is forbidden. Carry out selective sorting according to local regulations.

1 SYMBOLS USED IN THIS GUIDE

This guide uses symbols to highlight specific texts. The functions of each symbol are explained below:

▲ Safety warnings to prevent accident or injury.

🔑 Important details which must be respected for correct assembly and operation.

i Additional information to help the installer.

♻️ Information on caring for the environment.

2 IMPORTANCE OF THIS GUIDE

▲ Read this guide in its entirety before carrying out the installation, and follow all instructions. Failure to do so may result in a defective installation, leading to accidents and failures.

i This also guide provides valuable information to help you to carry out installation more efficiently.

🔑 This guide is an integral part of the product. Keep for future reference.

3 ENVISAGED USE

This operator has been designed exclusively to be installed to automate sliding pedestrian doors in dry environments.

▲ This operator is not suitable for installation in inflammable or explosive environments.

▲ Failure to install or use as indicated in this guide is inappropriate and hazardous, and could lead to accidents or failures.

▲ The installer shall be responsible for ensuring the facility is set up for its envisaged use.

4 INSTALLER'S QUALIFICATIONS

▲ Installation should be completed by a professional installer, complying with the following requirements:

- He/she must be able to perform simple electrical installations in line with the low voltage regulations and applicable standards.

- He/she must be able to perform simple mechanical installations.

▲ Installation should be carried out taking into account Standards EN16005.

5 OPERATOR SAFETY ELEMENTS

This operator meets all current safety standards. However, the complete system includes, in addition to the operator mentioned in these instructions, other elements that must be purchased separately.

🔑 The safety of the complete installation depends on all the elements installed. Install only Erreka components in order to guarantee proper operation.

▲ Respect the instructions for all the elements used in the installation.

▲ Installing safety elements is recommended.

i For further information, see "Fig. 1 Elements of the complete installation" on page 7".

6 DANGERS IN THE CLOSING EDGES

▲ There may be a risk of crushing, trapping, collision and dragging in the different closing edges of the automatic doors.

7 MANUAL REVIEW

Manual review: 01

- Hardware Review: DOOP_2.6.
- Software version: 1.1.2.

1 PRE-INSTALLATION AND COMPLETE INSTALLATION ELEMENTS

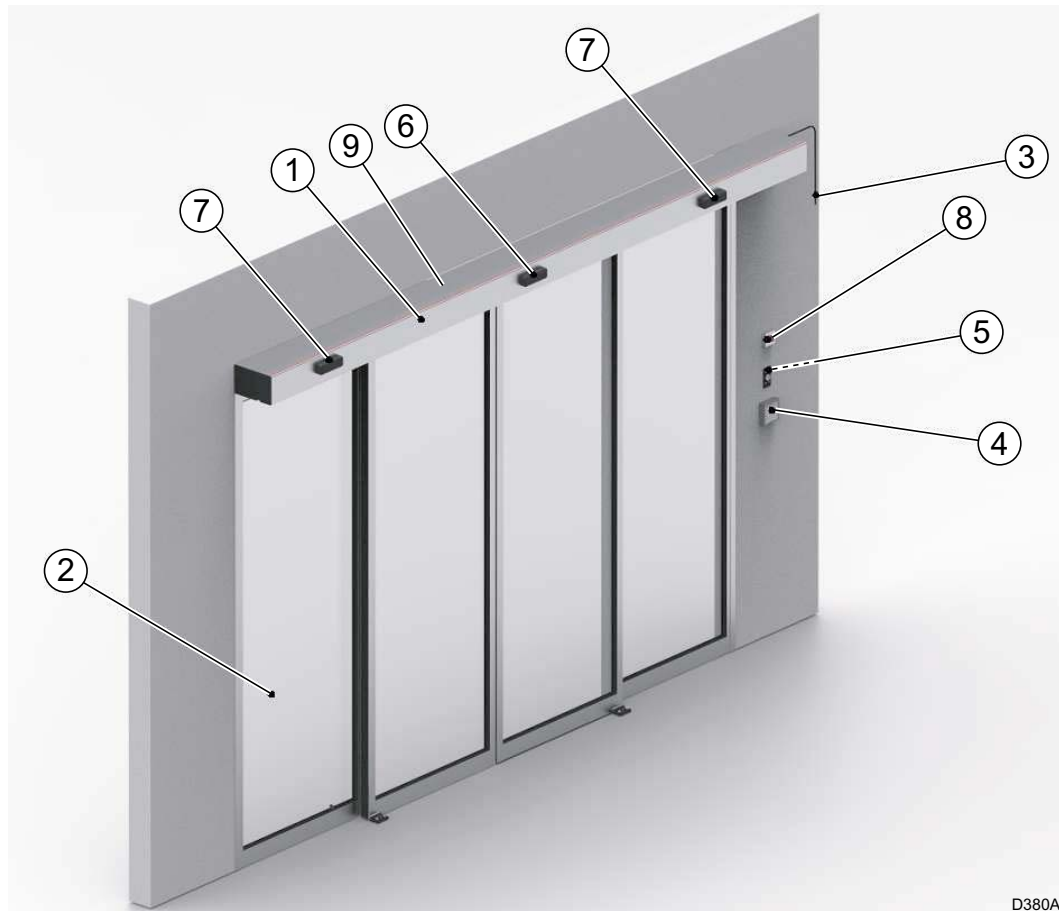

D380A

- | | |
|---------------------------------|-----------------------------------|
| 1 Operator | 6 Activation sensors + photocells |
| 2 Leaves | 7 Safety sensors |
| 3 Power input | 8 Emergency pushbutton |
| 4 Functions selector | 9 SmartCard CONNECT module |
| 5 Exterior key (on the outside) | |

ELECTRICAL WIRING:

Element	N° wires x section	Maximum length	Observations
Main power supply	3 x 1.5 mm ²	30 m	For longer lengths, please ask
Functions selector	4 x 0.5 mm ²	25 m	For longer lengths, please ask Screened cable
Safety sensor	6 x 0.5 mm ²	20 m	
Radar + Photocell	8 x 0.5 mm ²	20 m	
Exterior key	3 x 0.5 mm ²	50 m	
Emergency	2 x 0.5 mm ²	50 m	
Electrolock	4 x 0.5 mm ²	6 m	With test; two more wires
SmartCard CONNECT module	UTP 4 pairs Cat 6	0.5 m	Code ERREKA cable: ACN02

Fig. 1 Elements of the complete installation

2 CHARACTERISTICS OF OPERATORS RUN10/15 and RUN10P/15P

Description of general operation

The RUN 10/15 and RUN 10P/15P operators for sliding doors are built to automate pedestrian sliding doors.

These operators are designed to automate doors with one or two moving leafs.

General characteristics

Differences between RUN10/15 and RUN10P/15P operators

The RUN10 and RUN10P operators are mechanically identical. The only difference between them is the motor and therefore the power. The RUN10 operator has the standard motor for doors weighing up to 140 kg, while the RUN10P operator has the more powerful motor, for doors weighing up to 200 kg.

Difference between RUN10/10P and RUN15/15P operators

The RUN10 and RUN10P operators have a standard 108 mm cover height, while the RUN15 and RUN15P operators have a high 150 mm cover. The latter can generally be used for profiles where the top frame is to be hidden so only glass is visible, without any frame. Also for cases where more internal space is required to include components that do not fit within the standard cover.

Technical characteristics

CHARACTERISTIC	R10 900 OPERATOR RUN10 / RUN15	R10P 900 OPERATOR RUN10P / RUN15P
Dimensions (RUN10 / RUN15)	108 x 170 mm / 150 x 170 mm	
Power supply (V/Hz) (*)	230 Vac - 50/60 Hz	
Clear opening (2 moving leaves)	900-3000 mm	
Clear opening (1 moving leaf)	800-3000 mm	
Maximum weight (2 leaves)	100 + 100 kg	140 + 140 kg
Maximum weight (1 leaf)	140 kg	200 kg
Maximum clear opening height	3000 mm	
Opening speed	0.2m/s-0.7m/s	
Closing speed	0.1m/s-0.5m/s	
Maximum power consumed (W)	100W	200W
Network input fuse	2 A (5X20)	
Peripherals power supply (voltage)	24VDC	
Peripherals power supply (current)	1.5A	
Operating temperature (°C)	-20°C to +50°C	
Batteries	NiCd (24V-800 mAh)	

(*): Operator version for 125 V ~ ($\pm 10\%$) / 60 Hz power supply available upon request

3 CHARACTERISTICS OF OPERATORS RUN10T / RUN15T

Description of general operation

The RUN10T / RUN15T operators for sliding doors are designed to automate telescopic pedestrian sliding doors.

These operators are designed to automate doors with 2 or 4 moving leaves.

General characteristics

Difference between operators

The RUN10T operator has a standard cover height of 108 mm, while the RUN15T operators have a high cover of 150 mm.

The latter can generally be used for profiles where the top frame is to be hidden so only glass is visible, without any frame. Also for cases where more internal space is required to include components that do not fit within the standard cover.



Technical characteristics

CHARACTERISTIC	R10P 900 OPERATOR RUN10T / RUN15T
Dimensions (RUN10 / RUN15)	108 x 249 mm / 150 x 249 mm
Power supply (V/Hz) (*)	230 Vac - 50/60 Hz
Clear opening (4 moving leaves)	1850-3800 mm
Clear opening (2 moving leaves)	1100-3800 mm
Maximum weight (4 leaves)	70 + 70 + 70 + 70 kg
Maximum weight (2 leaves)	100 + 100 kg
Maximum clear opening height	3000 mm
Opening speed	0.2m/s-0.7m/s
Closing speed	0.1m/s-0.5m/s
Maximum power consumed (W)	200W
Network input fuse	2 A (5X20)
Peripherals power supply (voltage)	24VDC
Peripherals power supply (current)	1.5A
Operating temperature (°C)	-20°C to +50°C
Batteries	NiCd (24V-800 mAh)

(*): Operator version for 125 V ~ (±10%) / 60 Hz power supply available upon request

1 OPERATION MODES

Automatic mode

This is the most usual way of working. It allows transit in both directions.

- **OPENING:** This begins by enabling the key device (activation sensor, transmitter, etc.).
- **STANDBY:** The door remains open for a programmed time. Standby time can be changed using the digital selector (see relevant section).

- **CLOSING:** The closing operation starts automatically once standby time has finished.

 It can be configured so the door works as SEMIAUTOMATIC (see description in special operating modes).

Door Open

The door opens and remains open in maximum opening position.

If the leaf is manually handled in an attempt to close it, the door will resist and the motor will exert force in order to maintain door open position.

Door Closed

The door closes and remains closed, ignoring activation sensors.

If the leaf is handled in an attempt to open the door, the motor will resist and attempt to maintain door closed position.

If an electrolock is available, it will lock the leaves in addition to closing them, preventing any manual opening of the door from the outside.

 **The door can only be opened by an external opening impulse (KB) or by changing mode from the selector.**

Exit only

The door operates in automatic mode, but only in one direction: exit direction to the outside. Only the interior activation sensors work. The exterior sensors will no longer activate opening towards the inside.

If the door has an electrical lock, it remains locked when closed (configurable from the selector).

 The door only responds to interior activation devices.

Winter or partial opening

This operation is the same as automatic mode, but with the leaves opening only partially instead of to the maximum opening point. The opening or clear opening is adjustable from the digital selector.

This mode works differently from the digital selector (DIG SELN1) or from the rotary key selector (ROT SELN1).

With the digital selector, the door operates by opening partially in all modes ("automatic", "exit only" and "door open") except for "manual" and "door closed" when winter mode is activated.

With the rotary selector, "winter mode" is a partial automatic mode and does not affect the other modes.

Manual mode

Manual mode stops the door and releases the motor. The leaves remain disengaged so they can be freely moved and manually positioned as required.

This mode is also very useful when installing the door with a manual lock, allowing the door and latch to be



closed manually without any motor interfering in the operation.

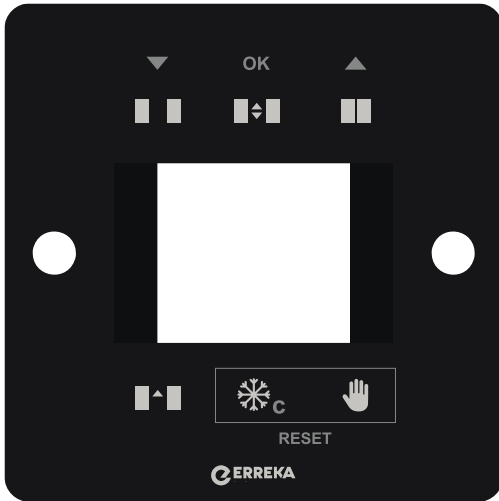

On leaving manual mode, the door will slowly move to closed position and then switch to the selected operating mode.

2 DIGITAL SELECTOR (DIG SELN1)



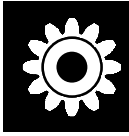

-  Door Open
-  Door Closed
-  Automatic
-  Exit only
-  Manual mode
-  Winter / Partial opening

▲ **Reset:** The door performs an automatic Reset when holding  and  down simultaneously for 3 seconds.

▲ **To lock the selector,** hold the  and  keys down for 3 seconds. Repeat the sequence to unlock. The screen shows the following icon when the selector is locked: .

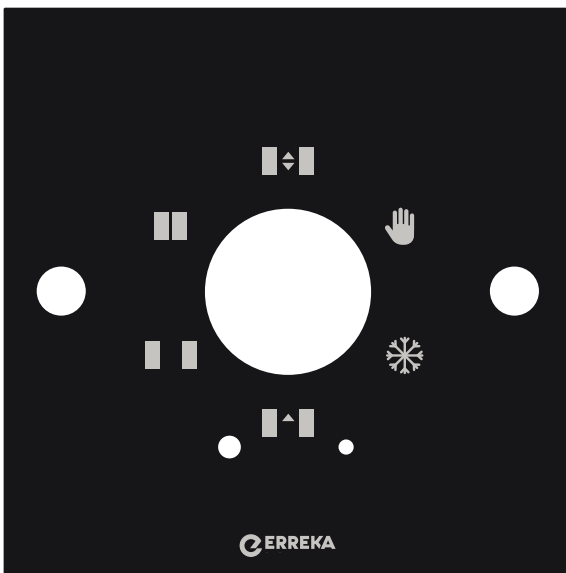
3 ROTARY SELECTOR (ROT SELN1)



-  Door Open
-  Door Closed
-  Automatic
-  Exit only
-  Manual mode
-  Winter / Partial automatic

▲ **To RESET,** press the concealed pushbutton to the right of the exit only icon using a tipped instrument. 

▲ **LED:**
 - Normal operation: flashing 1 second
 - Failure: fast flashing. 

▲ It is not possible to configure any door parameters with the rotary selector.

1 ELECTRONIC BOARD

Control board

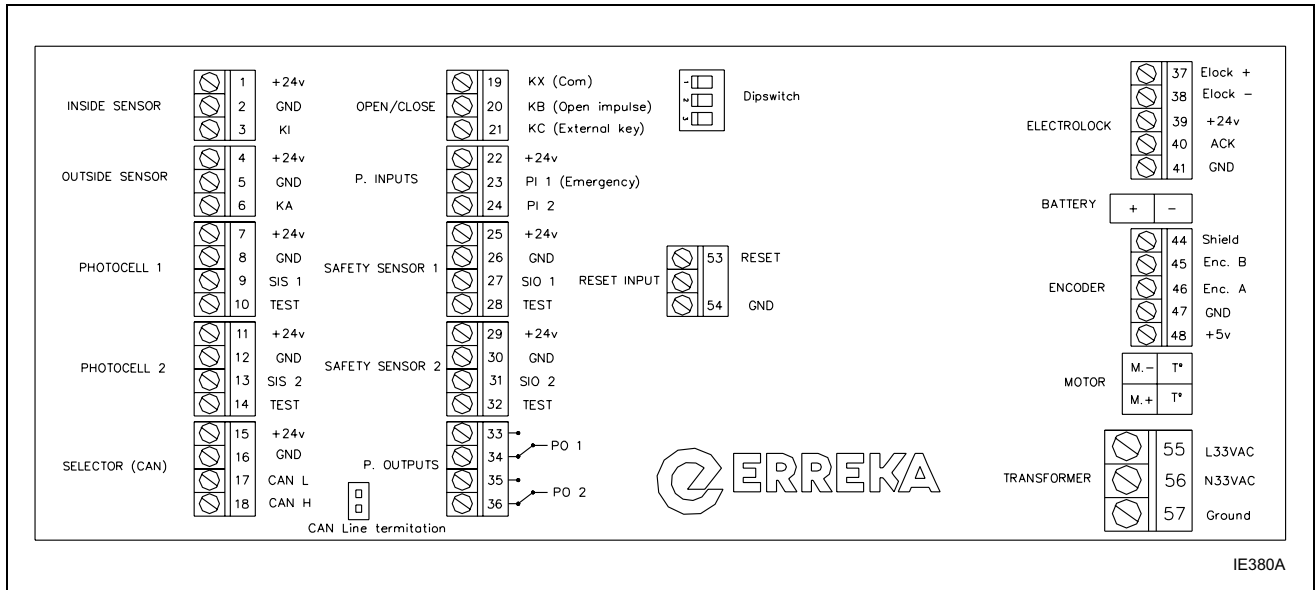

CONNECTORS MEANING

INSIDE SENSOR	Input cable connector strip: Interior activation sensor
OUTSIDE SENSOR	Input cable connector strip: Exterior activation sensor
PHOTOCELL 1	Input cable connector strip: Internal closing safety Photocell 1
PHOTOCELL 2	Input cable connector strip: External closing safety Photocell 2
SELECTOR (CAN)	Connector strip: CAN bus communication input, Selectors (digital or rotary)
OPEN/CLOSE	Input cable connector strip: Opening impulse and closing impulse (exterior key)
P. INPUTS	Connector strip: Programmable inputs (PI 1 and PI 2)
SAFETY SENSOR 1	Input cable connector strip: Safety sensor 1 in left opening
SAFETY SENSOR 2	Input cable connector strip: Safety sensor 2 in right opening
P. OUTPUTS	Connector strip: Programmable outputs (PO 1 and PO 2)
ELECTROLOCK	Electrolock input connector
BATTERY	Power input connector: Batteries (NiCd 24Vdc 800mAh)
ENCODER	Encoder input connector
MOTOR	Geared motor power connector + temperature sensor
TRANSFORMER	Power input connector: Power Supply
RESET INPUT	External Reset input connector
DIPSWITCH	Board address dipswitches

FUSES MEANING

F1	Fuse SMD 10 A "Littelfuse 0453019.MR" (battery protection fuse)
F2	Fuse SMD 10 A "Littelfuse 0453019.MR" (protection fuse power source-transformer 150 VA)



2 CONNECTING COMPONENTS AND PERIPHERALS

Operator board connections

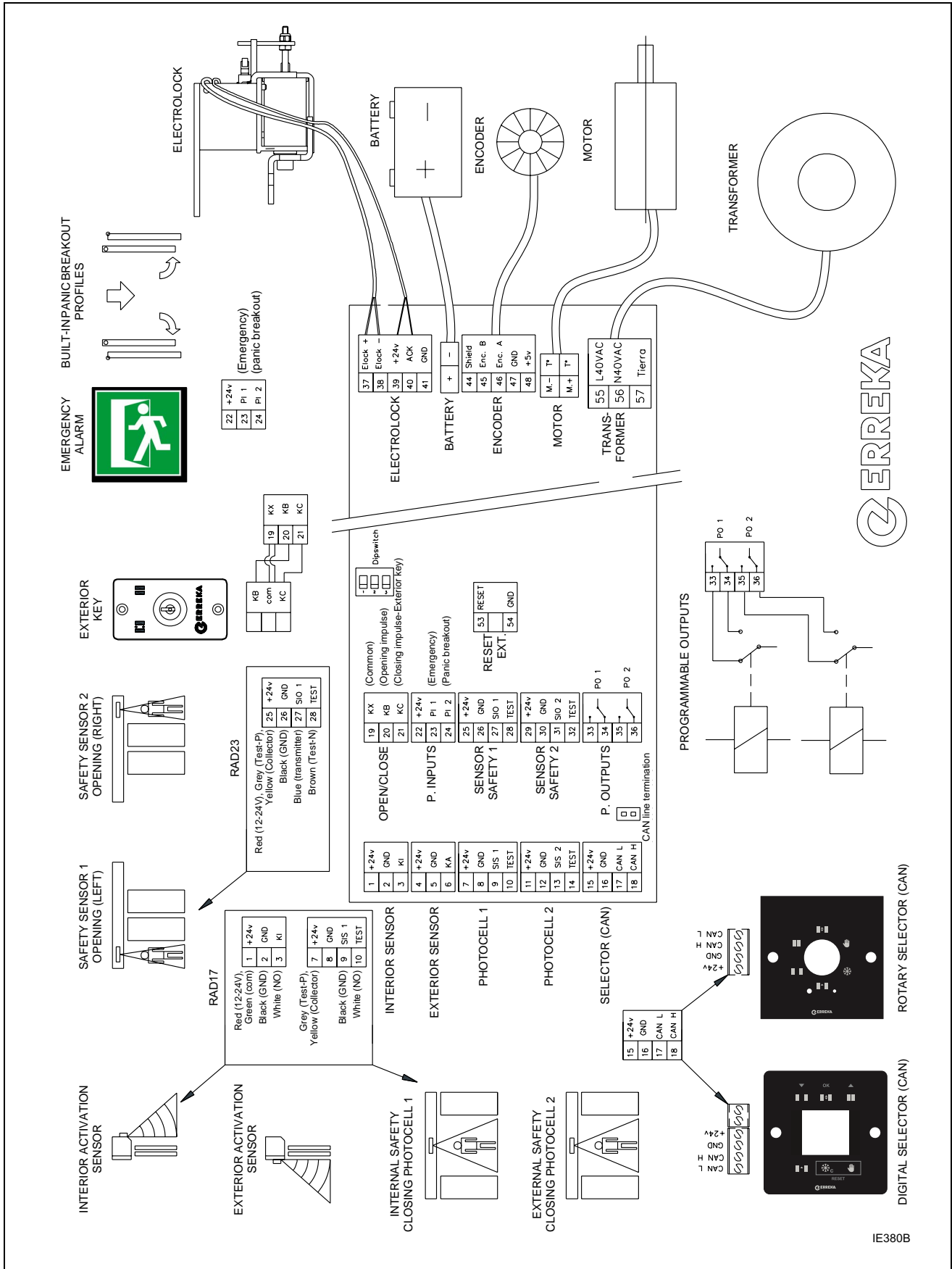

Network connection

✎ Passing the power cable through the right side of the machine is recommended. A cable with a minimum section of 1.5 mm² with three wires (phase L, earth PE, and neutral N).

⚠ Be sure to turn off the power before carrying out the following steps.

- 1 Pass the cable over the cable gland, clip it into the box profile, and connect it to the power supply.
- 2 Connect the power cables in the following order: connect the phase (L) to the top terminal, the neutral (N) to the bottom terminal, and the earth wire (PE) to the central terminal.

- 3 This will remove any static voltage; once the power cable is connected, secure the earth cable (which is separated from the power input board) to the chassis or the operator's bracket profile.

The power supply subassembly is made up of the transformer, batteries, and switch assembly. The switch assembly consists of an on/off switch and a 2A overcurrent protection fuse (*) (5 x 20 format). The latter is located beneath the plastic cover.

(*): The fuse in the 125V operator power supply version is 4A.

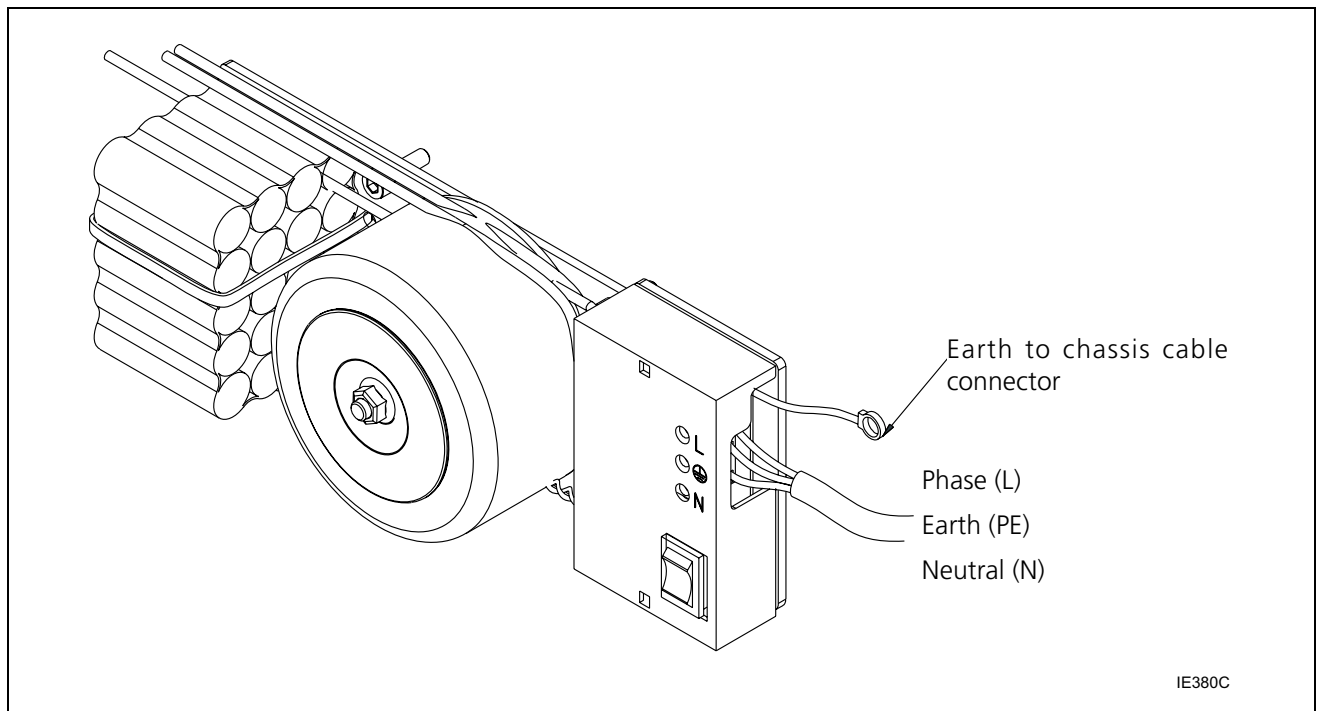

Sensors (Activation)

The activation sensors are the sensors that operate the door, opening it when it is closed or closing. Two units are normally installed in the central part of the machine, one inside the mechanism cover and the other outside on the mechanism bracket profile or lintel.

Connect the interior sensor directly to the control board, then run the cable from the exterior sensor to the left side of the motor through the lintel, make a hole through the box profile, and thread the cables through the cable glands to the control board.

For wiring, follow the diagram below.

Connections

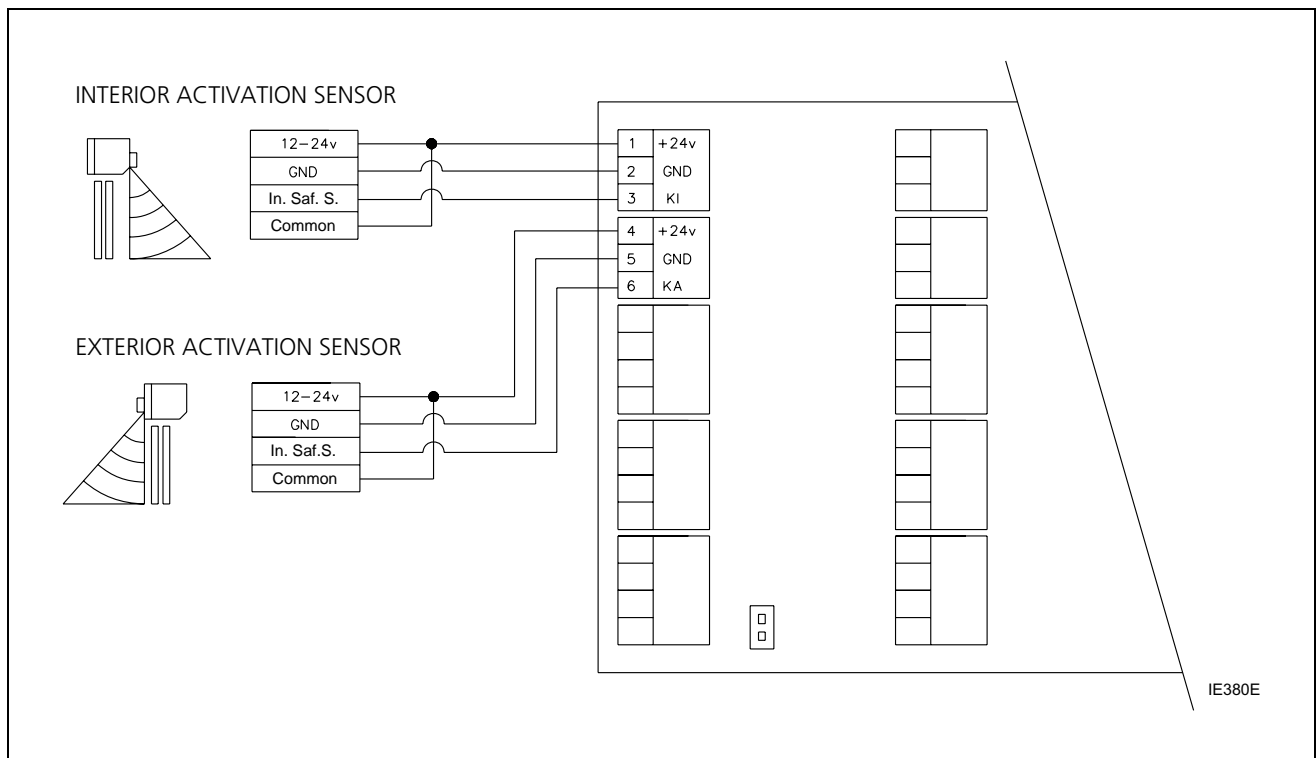

Activation sensor configuration

Enter the "Setup" menu: hold the following 3 keys down for 3 seconds: door open, door closed, and winter.

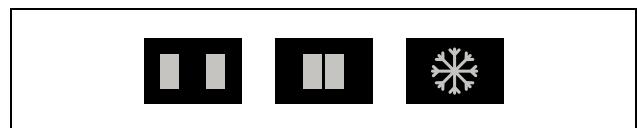

Once inside the menu, choose the following configuration for the internal and exterior sensors (case A: interior sensor / case B: exterior sensor):

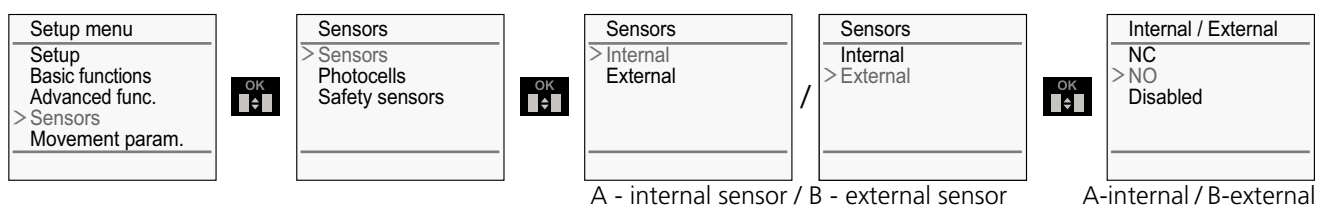

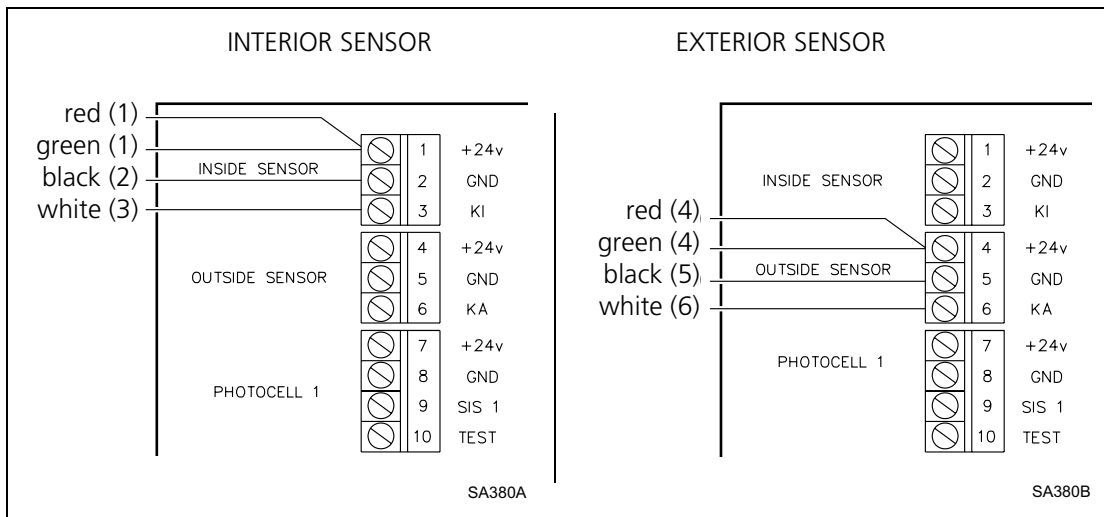

RAD17 (Hotron HR100-CT)

Board connections:

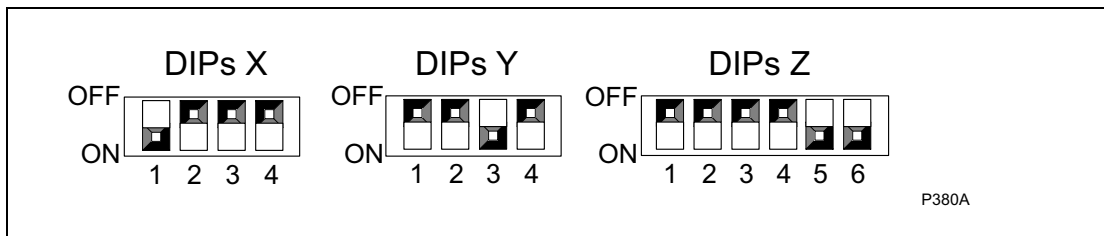

Sensor configuration:



 Z DIPs block, DIP2=OFF: Type of activation signal output Normally Open (NO).

RAD12 (Hotron SSR-3)

Board connections:

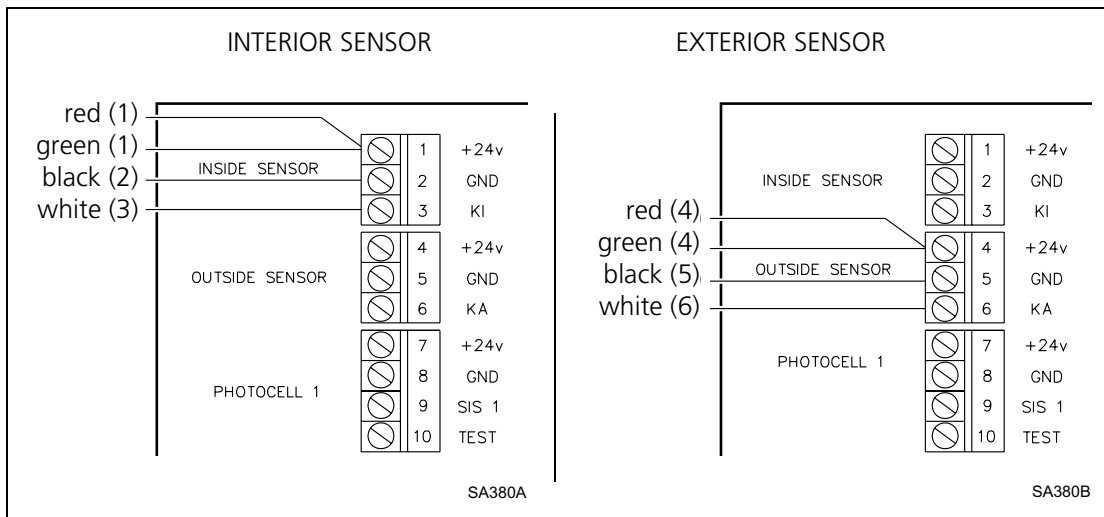

Sensor configuration:

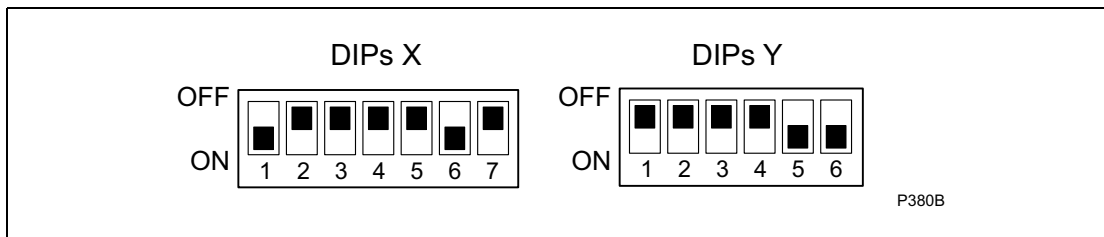

Y DIPs block, DIP2=OFF: Type of activation signal output Normally Open (NO).

RAD23 (Hotron 3H-IR14C)

Board connections:

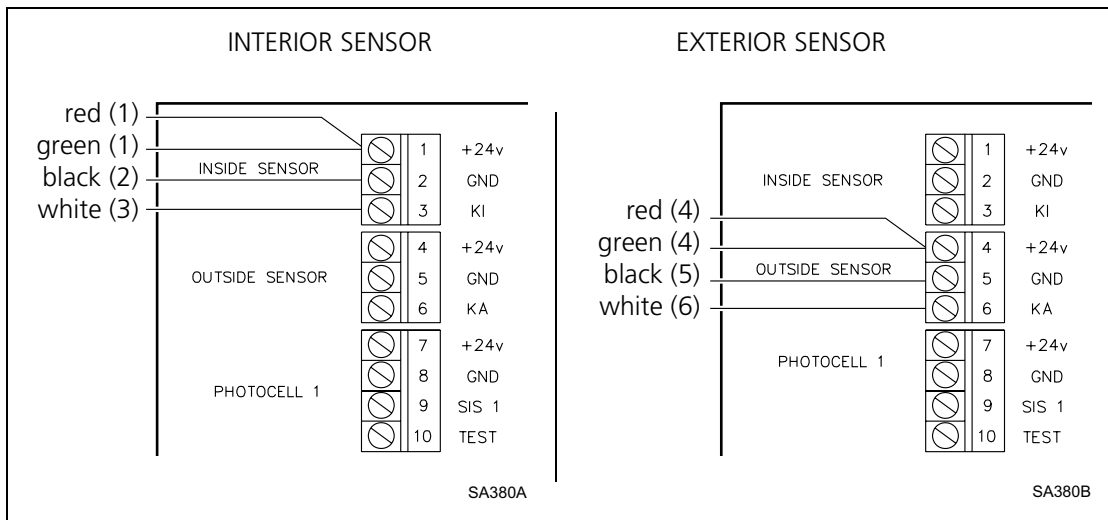

Sensor configuration:

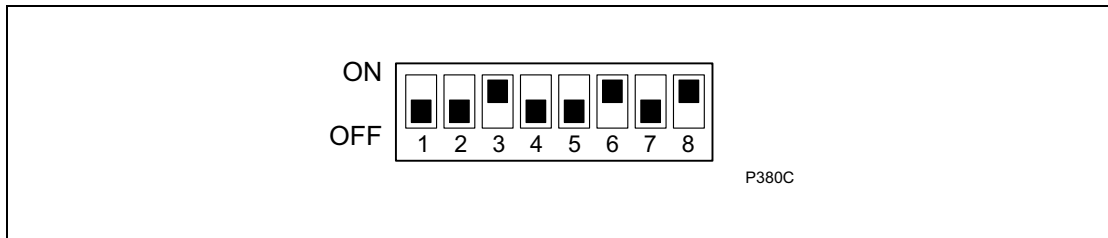

RAD13 (Hotron 3H-IR14)

Board connections:

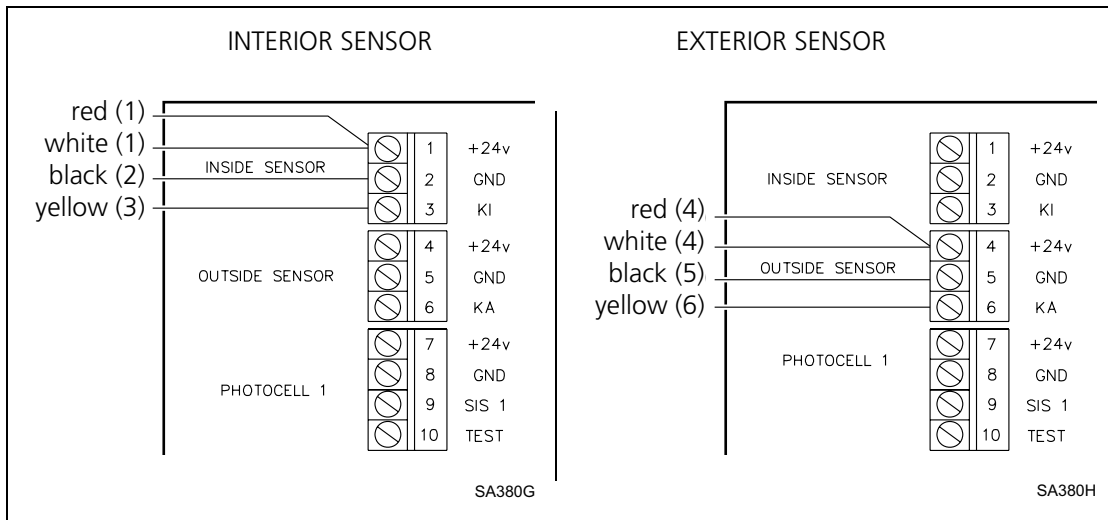

Sensor configuration:

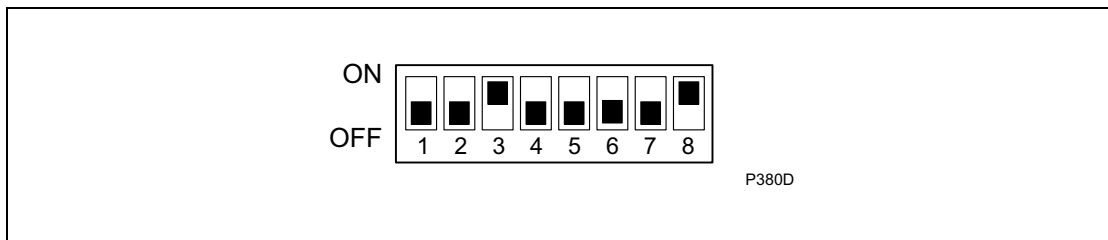

RAD9 (Hotron HR-50)

Board connections:

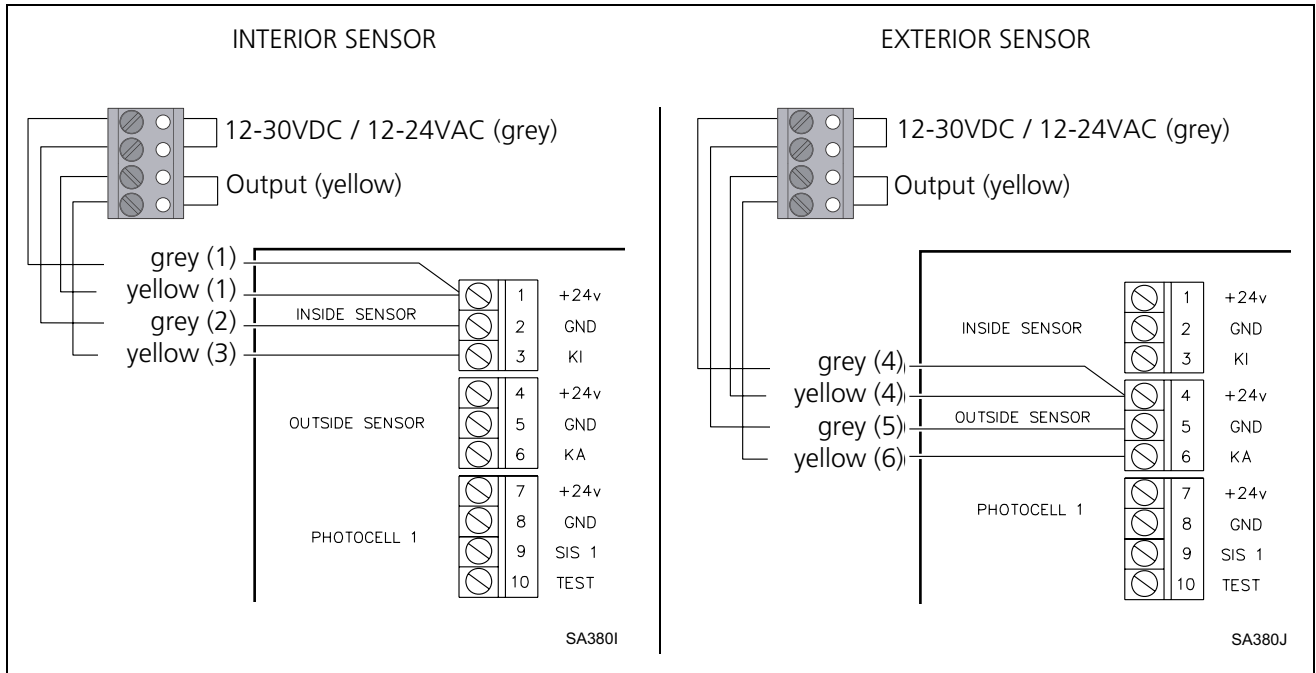

Sensor configuration:

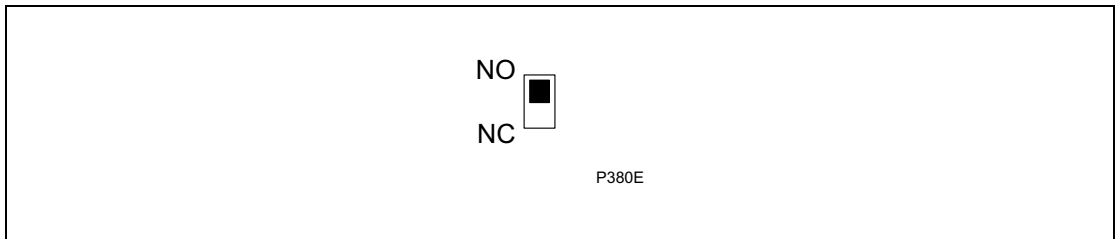

☞ DIP=NO: Type of activation signal output Normally Open (NO).

Photocells (Closing Safety)

The photocells prevent people from being trapped by the leaves during closing, quickly stopping and opening the door if anybody is detected in the operation. The door remains in the open position whenever the photocell detects presence.

Connections

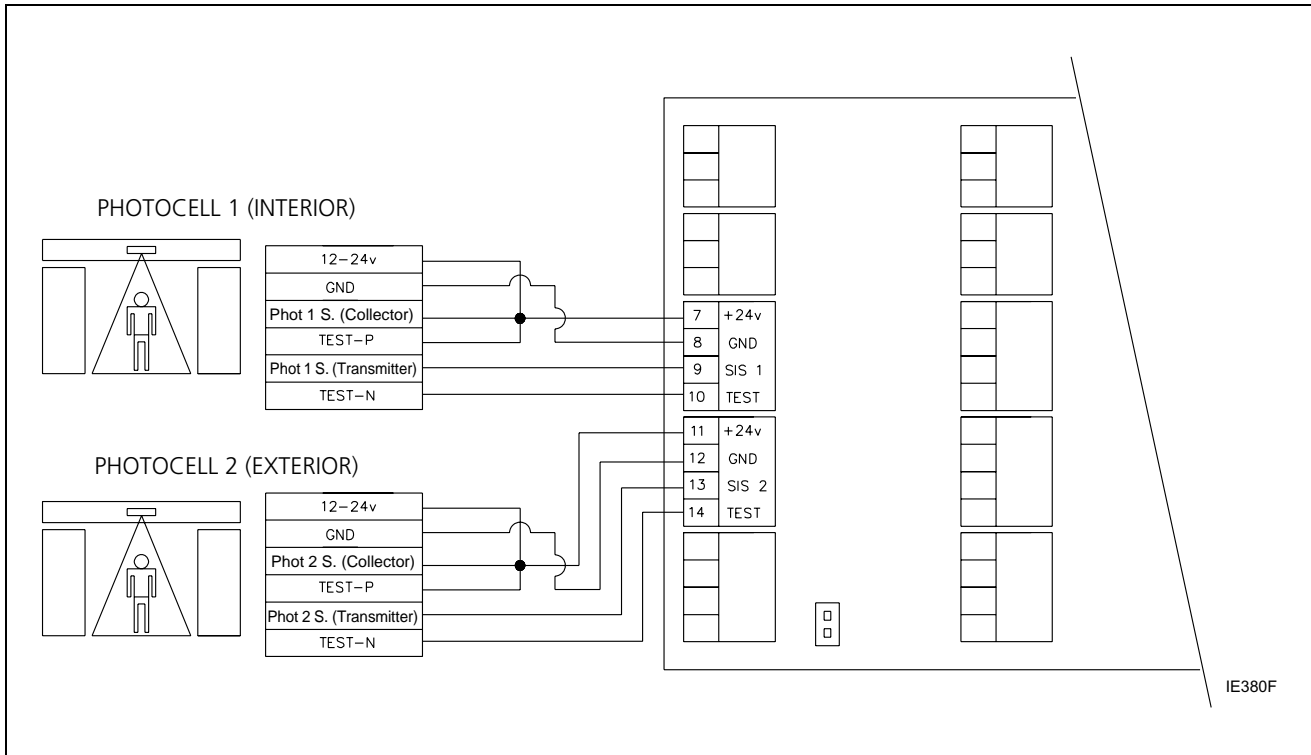

Photocell configuration

All photocells installed must have a test input to allow correct operation to be monitored, in accordance with Standard EN 16005. By default, the photocells are set to "Disabled". Go to configuration in the "Setup" menu if this input needs to be modified.

Enter the "Setup" menu: hold the following 3 keys down for 3 seconds: door open, door closed, and winter.

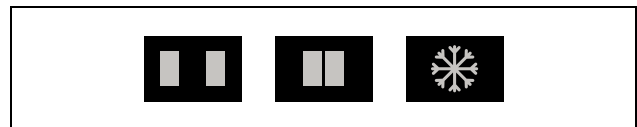

Once inside the menu, choose the following configuration for the internal and exterior photocells (case A: interior photocell / case B: exterior photocell):

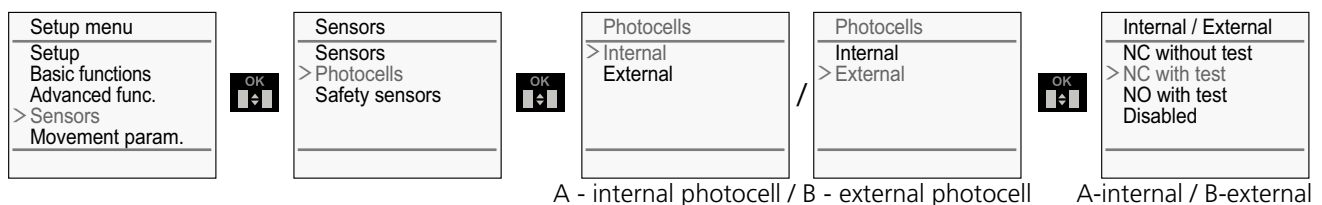

☞ To comply with Standard EN16005, adjust the sensor test according to the following diagram:

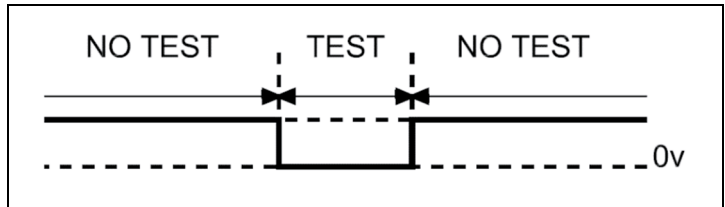

RAD17 (Hotron HR100-CT)

Board connections:

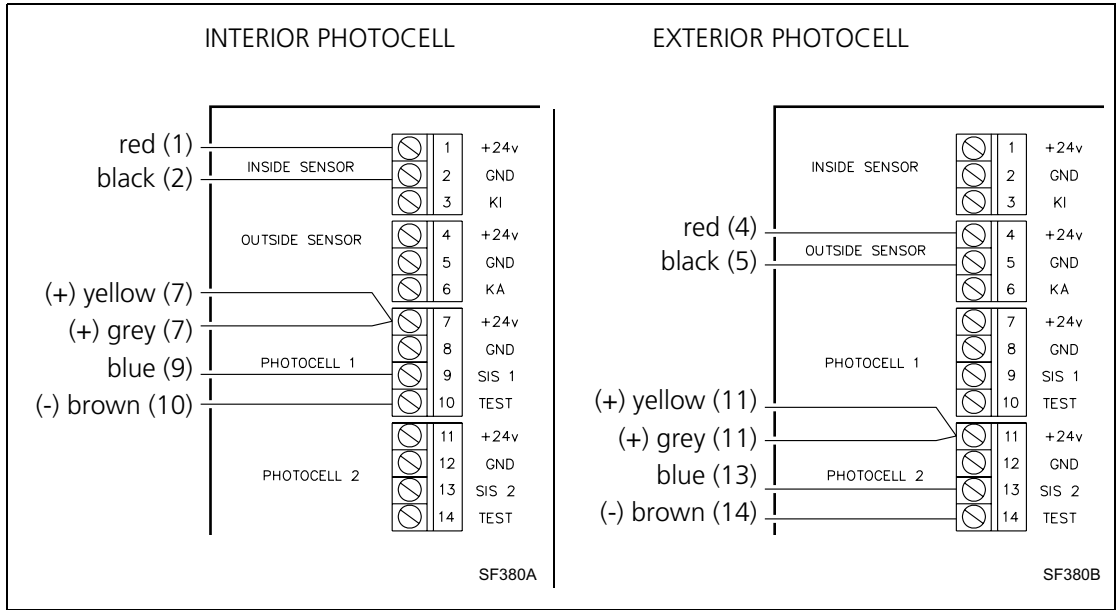

Sensor configuration:

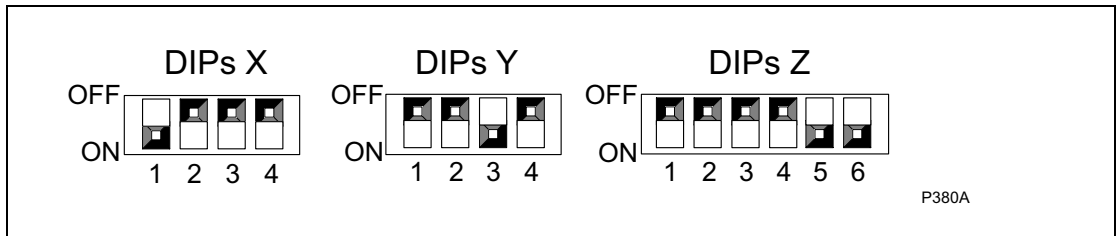

RAD12 (Hotron SSR-3)

Board connections:

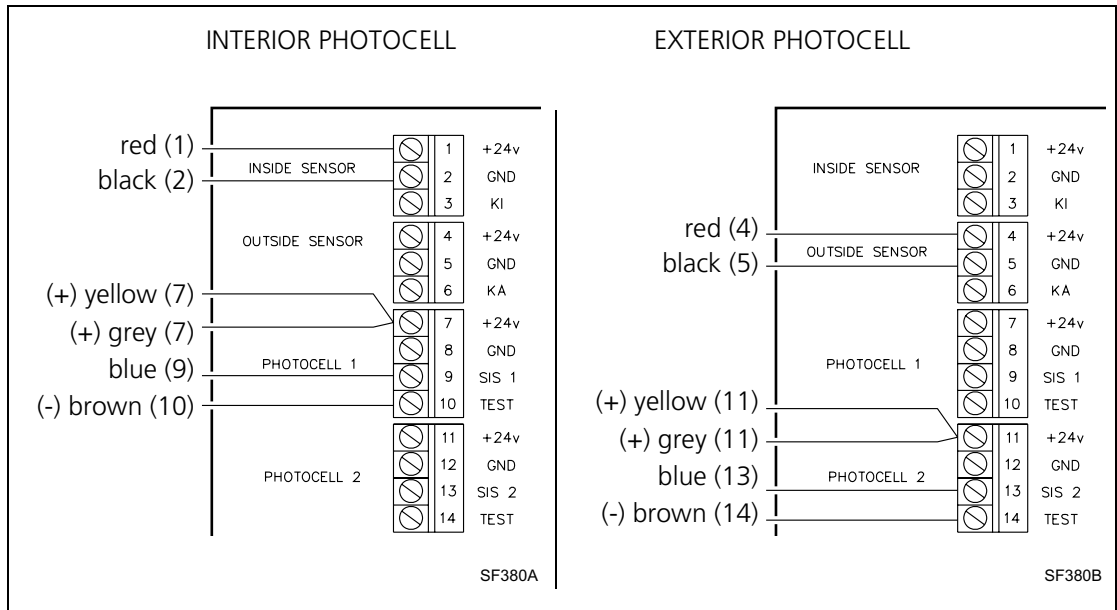

Sensor configuration:

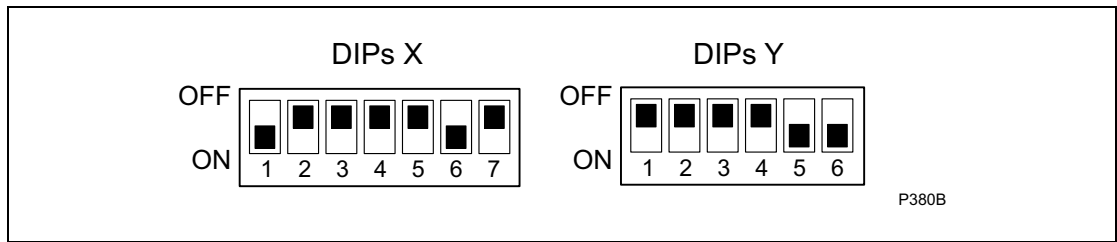

RAD23 (Hotron 3H-IR14C)

Board connections:

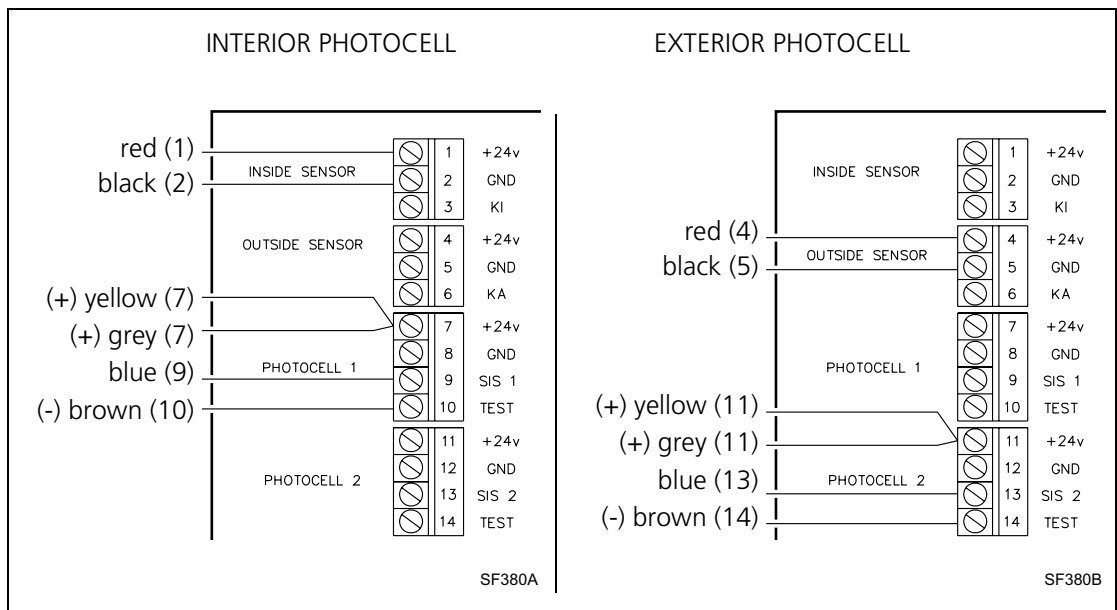

Sensor configuration:

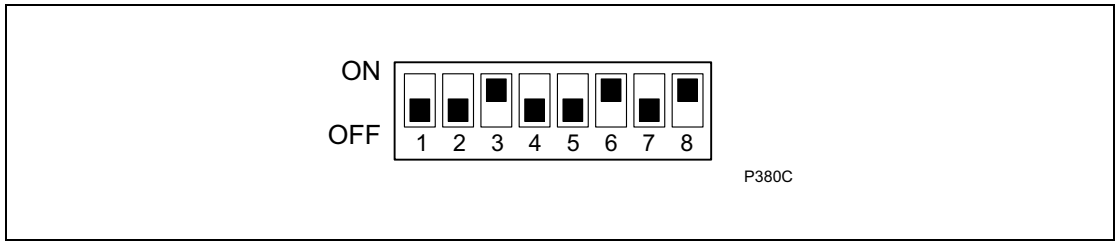

RAD 13 (Hotron 3H-IR14)

Board connections:

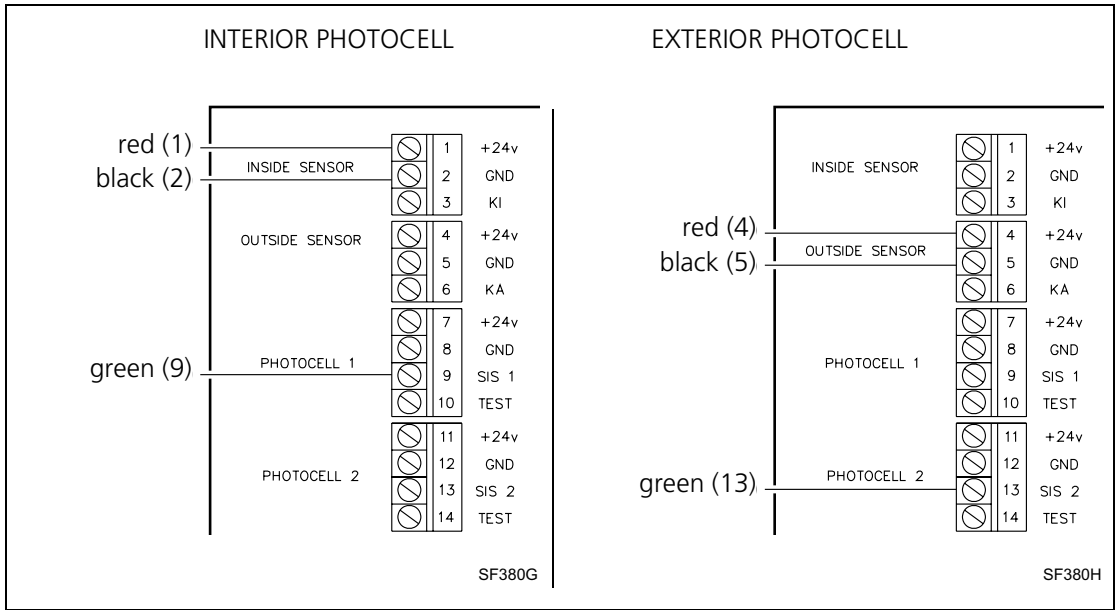

Sensor configuration:

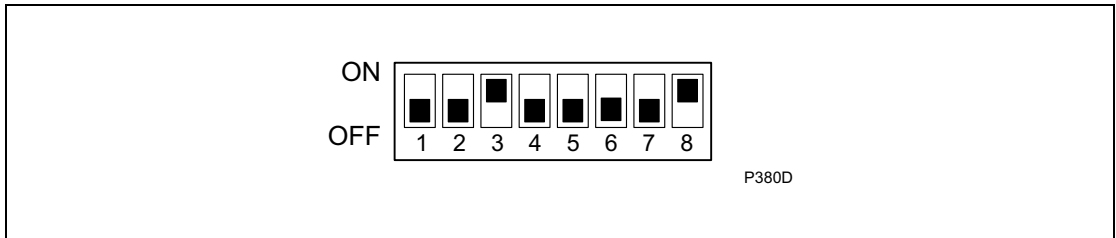

⚠ Caution: The photocell configuration must be NC without test.

Side safety sensors (Opening Safety)

The side safety sensors prevent anybody from being trapped during, stopping the operation and continuing slowly until fully open if anybody is detected in the opening line. They are installed in the central cover profile above each fixed leaf.

⚠ Caution: the door will always open at slow speed if an object is placed in the sensor detection area.

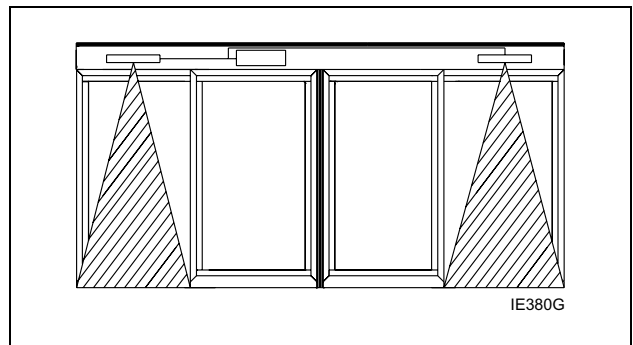

Connections diagram

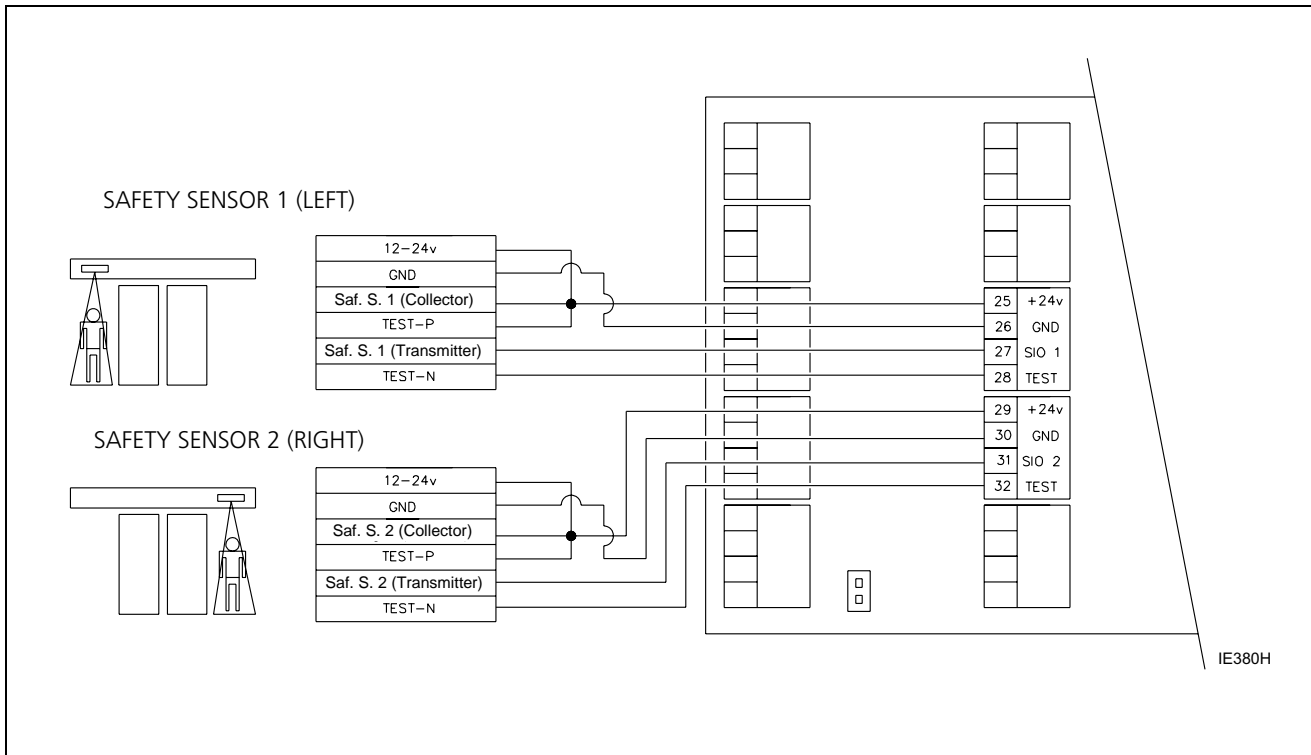

Side safety sensors configuration

The safety sensors installed must have a test input to monitor correct operation. By default, the side safety sensors will be set to "Disabled". Go to configuration in the "Setup" menu if this input needs to be modified.



Enter the "Setup" menu: hold the following 3 keys down for 3 seconds: door open, door closed, and winter.

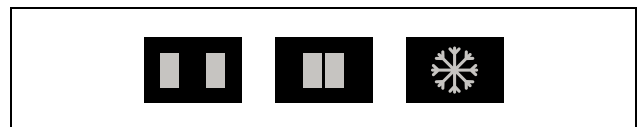

Once inside the menu, choose the following configuration for sensors 1 and 2:

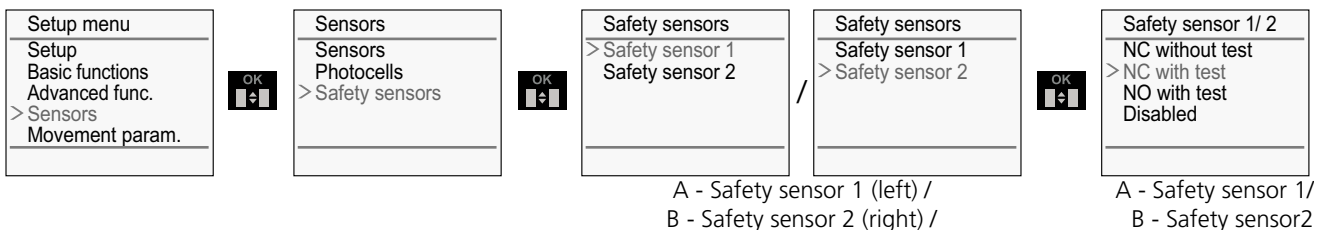

To comply with Standard EN16005, adjust the sensor test according to the following diagram:

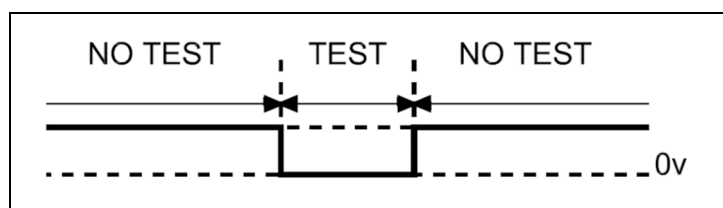

RAD23 (Hotron 3H-IR14C)

Board connections:

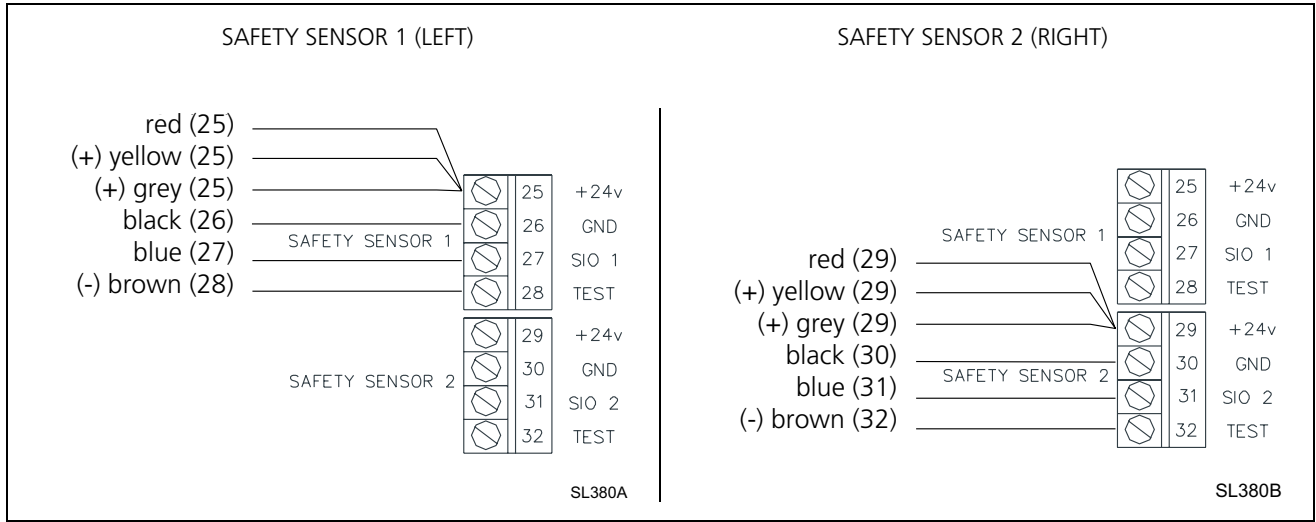

Sensor configuration:

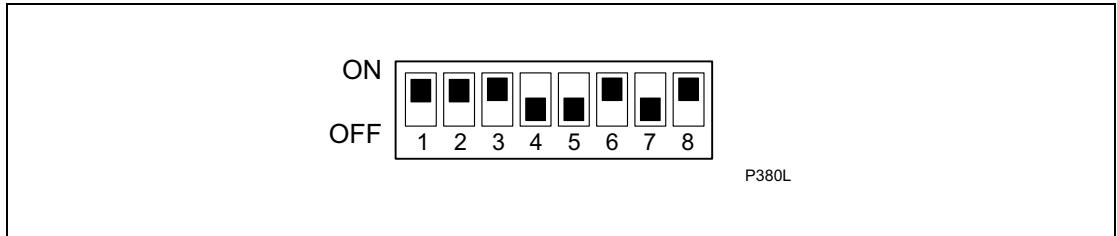

Electrolock

Two types of electrolocks may be installed in the door:

- Normally locked or R10 SECURELOCK: lock the door in the event of failure.
- Normally disengaged or R10 SAFELOCK: release the door in the event of failure.

The choice of module should therefore be based on the specific usage and installation characteristics:

- For doors in emergency exits or escape routes: electrolock R10 SAFELOCK.
- For doors not on escape routes but which must be normally closed for safety reasons: electrolock R10 SECURELOCK.

Connections

Electrolock R10 SECURELOCK

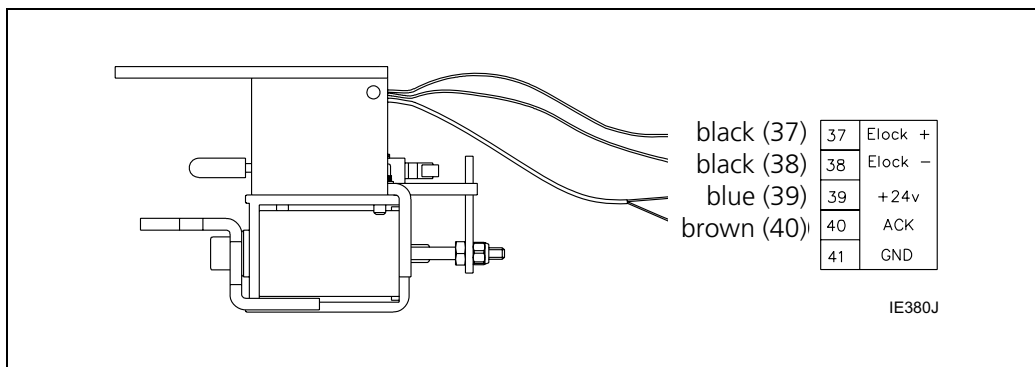

Electrolock R10 SAFELOCK

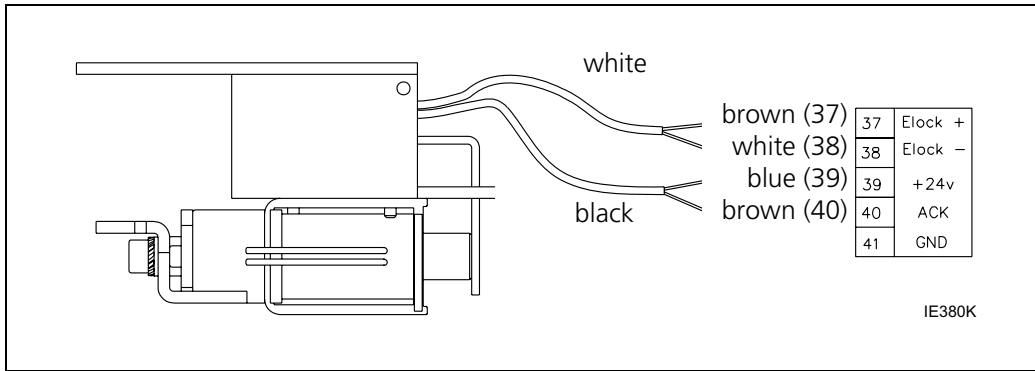

When installing the R10 SECURELOCK electrolock, it is recommended to install the manual release. The latch can therefore be unlocked manually in the event of no power or battery, or a fault in the machine.

Installing a lock release on the outside of the door is recommended if there is no other entrance to the premises, in order to unlock the door if necessary.

⚠ CAUTION: before starting up the operator, the R10 SECURELOCK electrolock must be kept unlocked (manual release handle) when installing and until configured.

Electrolock configuration

Enter the "Setup" menu: hold the following 3 keys down for 3 seconds: door open, door closed, and winter.

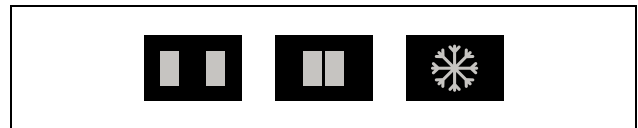

Once inside the menu, choose the following configuration for the electrolock, depending on the one installed:

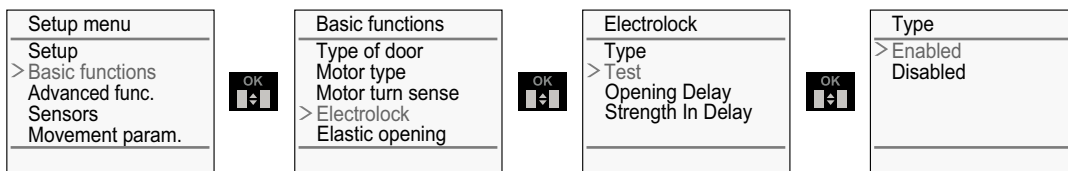
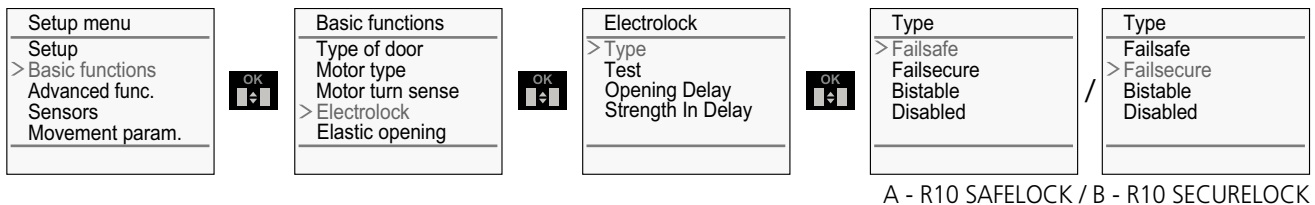

Digital selector (DIG SELN1)

⚠ CAUTION: it is essential to use a digital selector to start up the door.

The digital selector is the communication device between the control panel and the user, for control and to carry out the following tasks:

- 1 Choose different operator work modes.
- 2 Regulating operating parameters.
- 3 Enabling and disabling options.
- 4 Troubleshooting and Warning codes.

The digital selector consists of 6 pushbuttons for mode selection and access to various menus, and a display showing all the functions. The display typically remains in power-saving mode until a button is pressed, at which point the backlight brightens to make the contents easier to see.

While the door is operating, the display indicates the operating mode selected at this time.

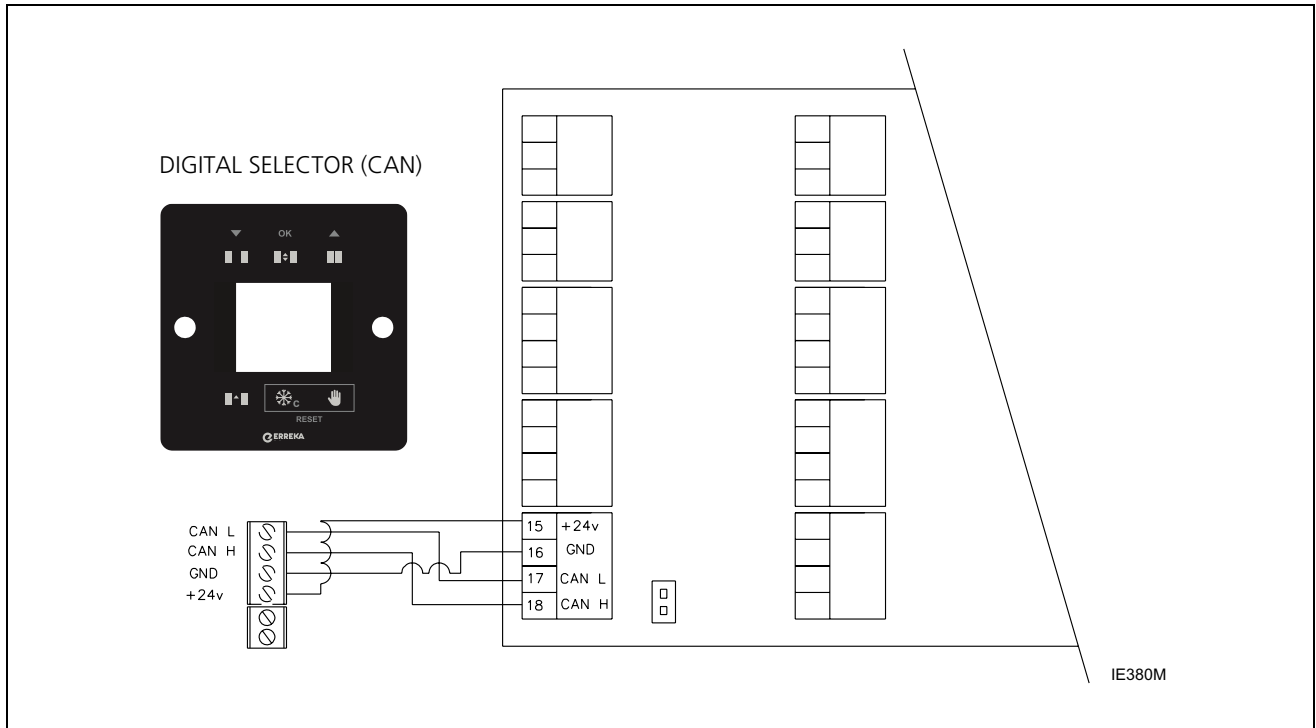

- **To lock the selector** to ensure it cannot be tampered with and the modes and parameters cannot be changed: hold the following keys down for 3 seconds: automatic  and manual



- **To unlock:** repeat the sequence.

There is also an option to lock the digital selector to prevent unauthorised use: on the digital selector, there is an input marked with a padlock where a contact key can be connected so the selector cannot be used when the contact is closed.

Terminals with closed contact for locking:

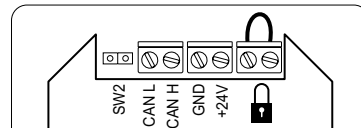

Terminal blocks with open contact for unlocking:

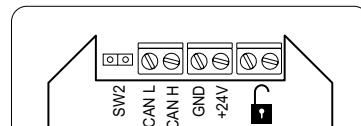

Access to various menus and configurations is explained in section 9.

Rotary selector (ROT SELN1)

Like the digital selector, the rotary selector serves as a communication device with the board, although its functions are more limited. The mechanism cannot be configured via this device.

The functions that can be performed are:

- 1 Choose different operator work modes.
- 2 Troubleshooting (no difference between Warning codes). A Warning is only signalled with an LED. A digital selector must be connected in order to see the specific message. A one-second flash shows that the operator is working properly, while fast flashing shows that there is a Warning.

The device consists of a 6-position key switch, so each position equates to an work mode. The work modes can only be activated or changed with the key.

It also has a Reset pushbutton. This button allows a Reset by holding down for several seconds. The operator will perform a restart process that will be completed with an opening and closing sequence of the leaf/leaves.

✎ It is NOT possible to use the ROT SELN1 rotary selector in combination with the DIG SELN1 digital selector.

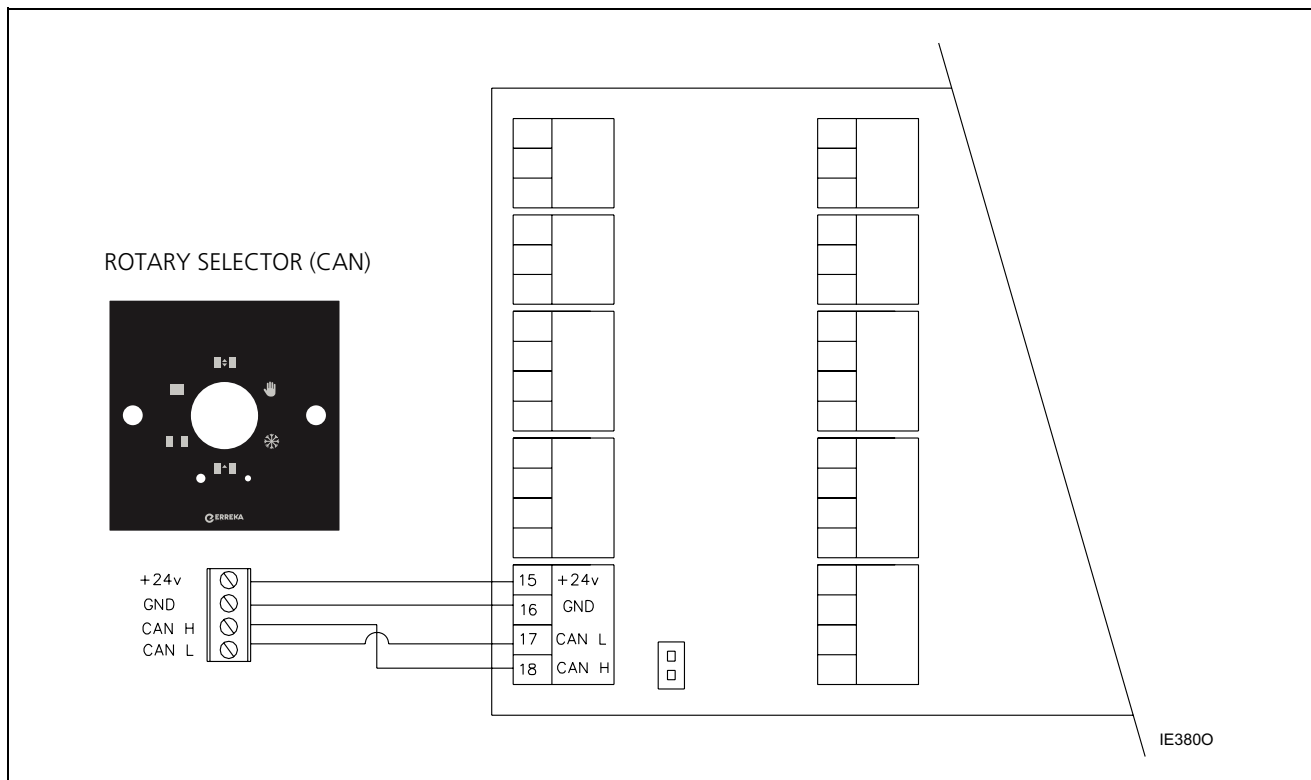

Opening impulse / Closing impulse (exterior key)

These are inputs that allow direction to be opened and closed outside of the work modes commonly allowed by the mode selectors. Inputs are pulse type and each activation opens or closes the door. The KB input allows the door to be opened, and the KC input allows to be closed.

Various types of devices can be connected to these inputs. The most common would be an exterior key with two positions, one for opening and one for closing. Likewise, any device that can activate these signals, such as keys, magnetic cards, receiver, access control, etc., can be connected.

The function or behaviour for each input is as follows:

Opening impulse function (KB)

Each KB pulse opens the door and also sets the operator to the working mode currently selected by the function selector. This input has priority over the closing input, so opening continues to run even if KC is activated.

If the operator has no mains power, even in power-saving mode, a KB pulse activates the battery in order to carry out the opening operation with battery power.

Closing impulse function (KC)

This input orders the operator to close the door in Night Mode, this mode being different from the Door Closed mode of the selector working modes. Use of the digital selector is disabled in this mode, i.e. the operator ignores any actions on the mode selector while in night mode.

Each KC input activation will take the door from its current position to closed. The only way to exit this mode is by acting on KB or opening impulse.

If mains power is not available, each KC pulse moves the door to closed position with battery power.

Connection

Opening impulse (KB)

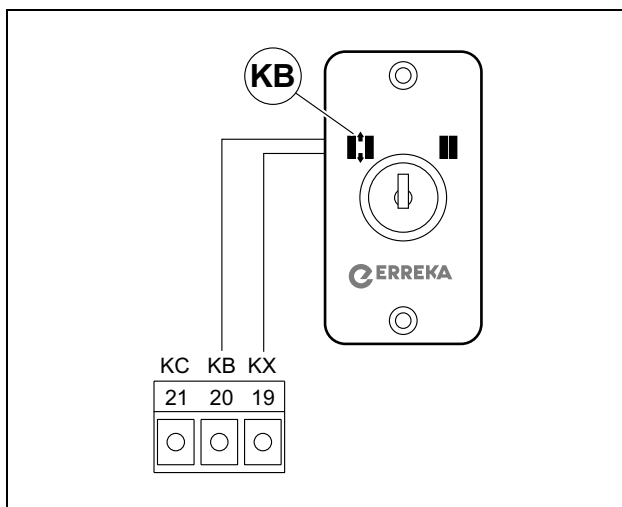

Closing impulse (KC)

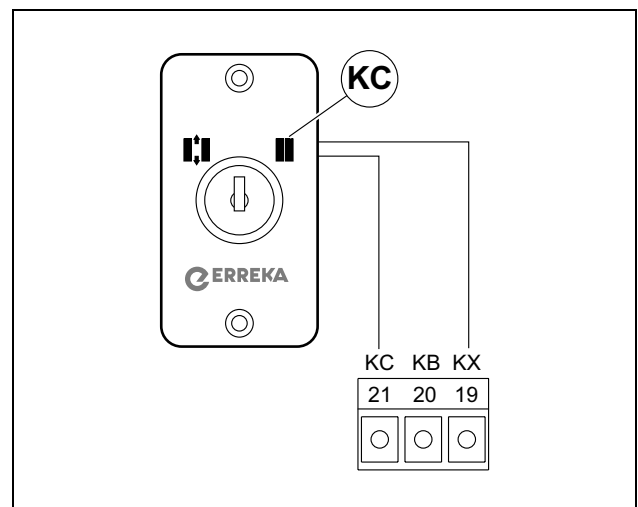

⚠ CAUTION: load cannot be connected to the KX input (com). Peripherals cannot be powered from this input.

Battery-operated opening system

Description

The operator has NiCd batteries, which generate 24V voltage and have capacity of 800 mAh.

There are three operating modes related to the battery system, configurable from the digital selector when setting up the operator: emergency, autonomous and no battery.

Emergency operating mode (EN 16005)

In this mode, the battery system's function is basically to open the door and keep it in this position (door open) when the mains power fails. It will remain open for as long as there is no mains power in all operating modes except door closed and manual modes. In door closed mode, the door will remain closed even if the power fails. The door will not move in manual mode as the motor is de-energised.

In those modes in which the battery system takes the door to open position in the event of a power failure, the door will switch to manual mode once open, in which case it can be closed at any time by switching to door closed mode from the functions switch or with an external close signal (KC).

The digital selector will show Warning code 17 for as long as the door has no power.

Warning code 17 will disappear as soon as the operator is powered by the mains again, returning to the previous working mode.

The operator switches to energy-saving mode if mains power is absent for one hour, turning off all door and operator peripherals. The operator will come on again if the mains power is restored or there is an opening (KB) or closing (KC) pulse. In the first case it will return to normal operation, while in the second case the required operation will be performed (open or close the door).

Autonomous operating mode

In this mode, the battery system's function is for the door to continue to operate in the same way in the absence of mains power. The operator will continue in the same working mode as before, although the opening and closing operations will be slower by default than when powered; these speeds can be configured via the digital selector. The switch will also show Warning code 17 whenever there is no mains power.

The door will switch to open or closed position in accordance with the current working mode whenever the battery level drops below a threshold value, and switch to energy-saving mode by turning off all the system's peripherals after 10 minutes on standby. The operator will come on again as soon as the mains power is restored, or if the door is operated by the KB or KC signals. In the first case it will return to normal operation, while in the second case the required operation will be performed (open or close the door).

No battery operating mode

In this operating mode, the operator can run without a battery system connected to the electronic panel. The operator will switch off directly whenever there is no power, and switch on when the mains supply is restored, returning to the previous working mode.

If batteries are connected, they will not be charged and their presence will not affect the previously described behaviour. In this operating mode, the absence of batteries or the fact they are flat will not show Warning codes 21 and 22, since there is no monitoring of the battery system's voltage and current.

- ⚠ CAUTION: load cannot be connected to the KX input (com). Peripherals cannot be used in this input.
- ⚠ CAUTION: the operator will display Warning codes 21 and 22 respectively on the switch's screen if the batteries are disconnected or damaged. The presence or status of the battery must be checked at the start and at regular intervals.

The limit value is calculated to guarantee a minimum of 100 complete operations during a maximum of 12 hours in doors close to the size and weight limit under optimal battery conditions, and always to guarantee that an opening or closing operation can be carried out whenever this value is exceeded by the KB and/or KC signals.

- ⚠ CAUTION: batteries are required in this operating mode. The system will display Warning codes 21 and 22 respectively whenever no batteries are connected or they are flat.

⚠ CAUTION: this battery system operating mode does not comply with standard EN 16005.



⚠ CAUTION: this battery system operating mode does not comply with standard EN 16005.

Battery mode configuration

The operator's default operating mode for the battery system is emergency mode, which complies with EN16005.

Please follow the steps below if you wish to change the operating mode.

Enter the "Setup" menu: hold the following 3 keys down for 3 seconds: door open, door closed, and winter.

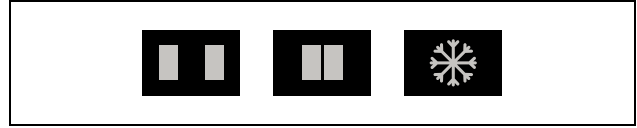

Once inside the menu, choose the following configuration for the battery system's operating mode:

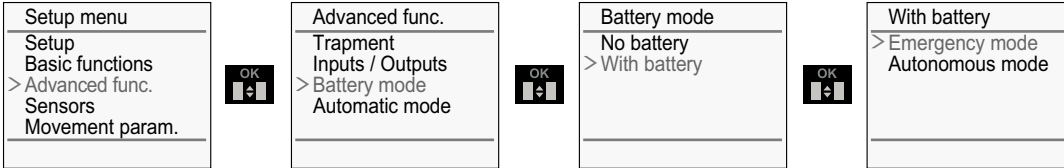

Once the operating mode is selected, the switch will show the chosen battery system's operating mode in the middle of the status line:

- Emergency operating mode (EN 16005): **E**
- Autonomous operating mode: **A**
- No battery operating mode: **X**

Automatic mode configuration

Description

There are two operating modes related to the Automatic work mode, which can be configured from the digital selector when setting up the operator: Normal and Semiautomatic.

Normal operating mode

This is the most common way of working. It allows transit in both directions.

STANDBY: the door remains open for a programmed time (configurable).

OPENING: starts by operating the key device (activation sensor, transmitter, etc.).

CLOSING: the closing operation starts automatically once standby time is finished.

Semiautomatic operating mode

OPENING: starts by operating the key device (activation sensor, transmitter, etc.).

▲ Use ONLY KI / KA inputs for Semiautomatic.

STANDBY: the door remains open.

CLOSING: the door closes automatically when the key device is enabled again.

Automatic mode configuration

Please follow the steps below if you wish to change the operating mode.

Enter the "Setup" menu: hold the following 3 keys down for 3 seconds: door open, door closed, and winter.

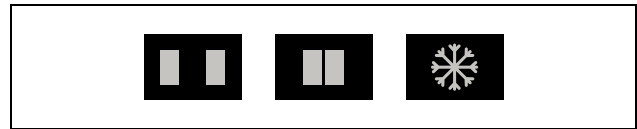

Once inside the menu, select the desired configuration for automatic mode operation mode:

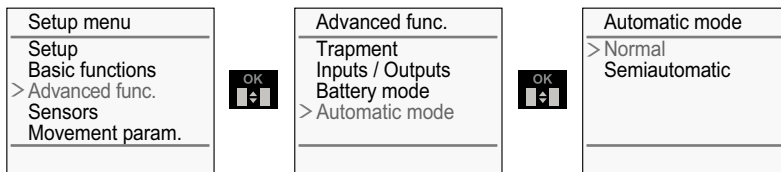

Programmable inputs PI1 and PI2

The following programmable inputs PI 1 and PI 2 can be configured from the selector:

- NC Continuous Emergency
- NO Continuous Emergency
- NC Impulse Emergency
- NO Pulse Emergency
- NC Panic breakout
- NO Panic breakout
- Disabled

Emergency / Fire protection

One of the inputs can be configured to be used as an input for the emergency or fire alarm. This is disabled by default. If required, both the type of signal (continuous or transient) and its activation (NO or NC) can be modified.

If the signal is set to continuous, the operator will automatically restore its function once the signal returns to normal operating configuration. If the signal is set to pulse, a Reset will be required to restore operation.

Panic breakout

One of the inputs can be configured to be used as an input with built-in panic breakout profiles. The profile's magnetic contact must be connected to this input so that it is possible to know if the door is opened in the event of an emergency. This is disabled by default. Activation can be modified if required (NO or NC).



Programmable outputs PO1 and PO2

The following programmable outputs can be configured from the selector:

- NC Closed door
- NO Closed door
- NC Warning Output
- NO Warning Output
- Disabled

Warning Signal

One of the outputs can be configured to provide a signal or relay contact closing whenever a Warning appears on the operator. Any device can be connected to remotely monitor the status of the door.

Closed Door Signal

One of the outputs can be set up to provide a signal or relay contact closing when the door is closed. It is an output suitable for connecting sounders or any device to determine whether the door is fully closed or not.

External reset input

The external Reset input (terminals 53 and 54) is used to perform a Reset on the operator when no function selector, either digital or rotary, is installed. In this case, it will be the only way to force the Reset operation if required. The operator will perform the restart process, but without carrying out the opening and closing sequence of the leaf/leaves.

A pushbutton or other element can be connected to the inputs, with the operator stopping and carrying the Reset operation when the contact is closed.

1 SETUP

Setup

Once the automation device has been installed, all peripherals are connected to the mains, and the function selector is connected as described in section "Connecting components and peripherals" on page 13, the following steps must be followed to complete operator setup:

- 1 Connect the batteries to the panel and turn on the startup switch on the power supply subassembly board on the right of the operator.
- 2 Ensure that the door begins a closing operation at a slow speed. At the same time, the digital selector lights up and the "RESET" icon is displayed after a few seconds (during which the ERREKA logo appears on the screen), indicating that the door is carrying out the setup procedure. The automatic opener must carry out a closing, full opening and closing operation.
- 3 Once the setup operation is complete, the switch will show Warning code 01, indicating that the door needs to be configured.

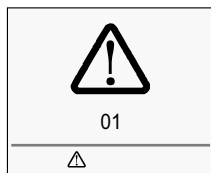

- 4 The Setup operation must be carried out. This can be done using the digital selector to enter the "Setup" menu by pressing and and .
- 5 Once inside the menu, activate the Setup operation by pressing three times.
- 6 The operator will start the Setup operation. It will first carry out a closing operation, then open up to the opening stopper, and finally close again at slow speed. It will then complete an opening cycle at normal speed to calculate the weight of the leaves. The door automatically changes to "Automatic" mode once the closing operation is completed.
- 7 The installed peripherals must be configured for the required operation after completing Setup. It is recommended to connect the accessories and configure them as indicated in section "Connecting components and peripherals" on page 13.

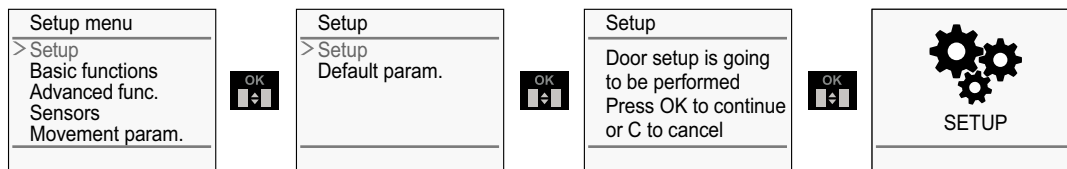

CAUTION: if the switch shows Warning codes 02 and/or 21 on screen, the door setup procedure cannot be carried out until these Warning codes have been removed.

Motor turning direction

The operator can be used to install the arms that join the moving leaves to the belt, such that they can open in both motor turning directions (clockwise and anticlockwise direction in opening).

Since the default option is clockwise direction, the door will open and close correctly once the operator has been set up, provided the arms have been installed according to the Mechanical Installation Guide. If the arms are installed contrary to the instructions in the manual, the door will work in reverse order after setting up the operator: it will close when an activation is detected, and stay open if nothing is detected.

Turning direction can therefore be changed using the digital selector. The steps to follow are:

Enter the "Setup" menu: hold the following 3 keys down for 3 seconds: door open, door closed, and

winter: ,  and .

Once inside the menu, go to the option for changing motor turning direction and confirm the chosen option:

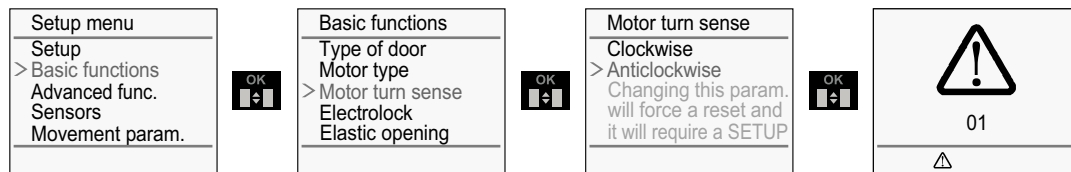

The operator will Reset and remain in closed position after performing the Reset operation, showing Warning code 01 in the digital selector to indicate that a setup operation is required.



All parameters referring to previously modified peripherals will keep their value.

2 REGULATING PARAMETERS





Adjustments can be accessed from any mode of work.

There are two parameter levels:

1 User level:  and .







2 Configuration or Technical Service Level: ,  and .

Once in the menu, navigate up or down in the menu using the following keys to choose the parameter to adjust:

- To **move down**:  and to **move up**: 
- To **accept, choose** or move **forward** in the submenus: 
- To **cancel** or go **back** in the submenus: 



More options are available via the selector:

- **Reset:**
 - **Operator Reset:** hold the following 2 keys down at the same time for 3 seconds:  and . The operator will perform a restart process that will be completed with an opening and closing sequence of the leaf/leaves.
 - **Selector Reset:** if communication between the operator and the digital selector is lost at any time, the selector must be Reset in order to restore communication within a few seconds by pressing the  and  keys. The selector will reconnect with the operator within no more than 30 seconds.
- **Lock:**
 - **Locking the switch** (so the modes and parameters cannot be tampered with or changed): hold the  and  keys down for 3 seconds.
 - **Unlocking the selector:** Repeat the same sequence as used to lock the selector.



1.- User Level

Accessed by holding the 2 keys down at the same time

for 3 seconds:  and .

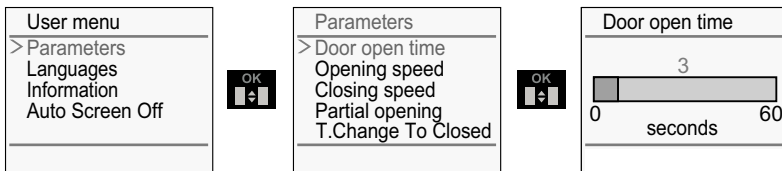
The following menu will be displayed on the selector screen:



The value will be adjusted using the  and  keys, and finally  to validate.

2.- Configuration or Technical Service Level

Accessed by holding the 3 keys down at the same time

for 3 seconds: ,  and .



This is the programming level for the technical service. It requires specific technical knowledge in order to adjust and regulate the correct parameters.

The following menu will display be displayed on the selector screen:

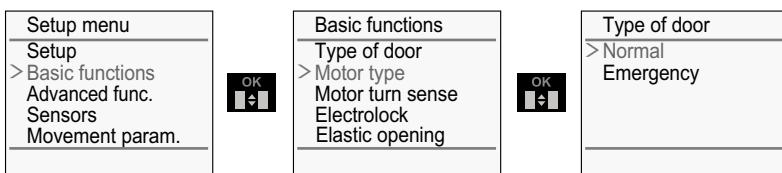

3 USER MENU

These are the parameters that can be configured from User Level:

1.1.- Parameters

1.1.1.- Door open time

Adjustable time (0 to 60 seconds, default value: 1)

1.1.2.- Opening speed Adjustable speed (+/-10% of the technician value)

1.1.3.- Closing speed. Adjustable speed (+/-10% of the technician value)

1.1.4.- Partial opening. Partial open door position (0 to maximum distance)

1.1.5.- T. change to closed. Delay time to switch to Closed mode (0 to 300 seconds, default value) 0)

1.2.- Languages

1.2.1.- Spanish

1.2.2.- English (default value)

1.2.3.- French

1.2.4.- Dutch

1.2.5.- Portuguese

1.2.6.- Basque

1.2.7.- Polish

1.3.- Information

1.3.1. - General

- Commis. date
- Operator type
- Serial number
- Last maint. date

1.3.2.- Machine

- Number of cycles
- Funct. time
 - Years
 - Months
 - Days
 - Hours
 - Minutes
- Cycles last mainten.
- Last Warning Code

1.5.- Auto screen off

- Disabled (default value)
- Enabled



4 SETUP MENU

Setup	
Setup	Door setup is going to be performed. Press OK to continue or C to cancel.
Default param.	Restore parameters to default values Press OK to continue or C to cancel.

Basic functions		
Type of door	Normal (default value)	
	Emergency	
		Elastic
Type of motor		Ertain / Run10
		Global / Run10P
Motor turn sensor		Clockwise
		Anticlockwise
Electro-lock	Type	<ul style="list-style-type: none"> • Failsafe • Failsecure • Bistable • Disabled (default value)
	Test	<ul style="list-style-type: none"> • Enabled • Disabled (default value)
	Opening delay	Value 0 to 10.000 msg (default value: 0)
	Strength in delay	Value 0 to 5 (default value: 0)
Elastic opening	Type	<ul style="list-style-type: none"> • Motor (default value) • Elastic
	Configuration	Elastic opening is going to be performed; press OK to continue or C to cancel.



Advanced func.		
Trapment	Sensitiveness	Value 1 to 5 (default value: 3) <ul style="list-style-type: none"> • 1: max. sensitiveness • 5: min. sensitiveness
	Mode	<ul style="list-style-type: none"> • Normal (default value) • Safe

Advanced func.		
Inputs / Outputs	Input 1	<ul style="list-style-type: none"> • Emerg. Cont. NC • Emerg. Cont. NO • Emerg. Imp. NC • Emerg. Imp. NO • NC Panic breakout • NO Panic breakout • Disabled (default value)
	Input 2	<ul style="list-style-type: none"> • Emerg. Cont. NC • Emerg. Cont. NO • Emerg. Imp. NC • Emerg. Imp. NO • NC Panic breakout • NO Panic breakout • Disabled (default value)
	Output 1	<ul style="list-style-type: none"> • NC Closed door • NO Closed door • NC Warning Output • NO Warning Output • Disabled (default value)
	Output 2	<ul style="list-style-type: none"> • NC Closed door • NO Closed door • NC Warning Output • NO Warning Output • Disabled (default value)
Battery mode	No battery	
	With battery	<ul style="list-style-type: none"> • Emergency mode (default value) • Autonomous mode
Automatic mode	Configuration	Normal (default value)
		Semiautomatic



Sensors		
Sensors (activation)	Interior	Configuration <ul style="list-style-type: none"> • NC • NO (default value) • Disabled
	Exterior	Configuration <ul style="list-style-type: none"> • NC • NO (default value) • Disabled
Photocells (closing)	Interior (Photocell 1)	<ul style="list-style-type: none"> • NC without test • NC with test • NO with test • Disabled (default value)
	Exterior (Photocell 2)	<ul style="list-style-type: none"> • NC without test • NC with test • NO with test • Disabled (default value)

Safety Sensor (opening)	Safety Sensor 1 (left)	<ul style="list-style-type: none"> • NC without test • NC with test • NO with test • Disabled (default value)
	Safety Sensor 2 (right)	<ul style="list-style-type: none"> • NC without test • NC with test • NO with test • Disabled (default value)

Movement param.		
Closing	Max. speed	Adjustable speed (100 to 500 mm/s; default value: 250)
	Batt. max. speed	Adjustable speed (100 to 500 mm/s; default value: 200)
	First acceleration	Adjustable acceleration (200 to 500 mm/s) ² ; default value: 350
	1st dec. position	Adjustable slowdown first initial position (25 to 75%)
	1st dec. final speed	Adjustable deceleration first final speed (50 to 250 mm/s; default value: 100)
	2nd dec. position	Adjustable slowdown second initial position (10 to 25%)
	2nd dec. final speed	Adjustable deceleration second final speed (20 to 100 mm/s; default value: 60)
	Final dec. pos.	Adjustable final slowdown start position (20 to 100 mm; default value: 50)
	Approach speed	Adjustable speed (20 to 100 mm/s; default value: 30)
Opening	Max. speed	Adjustable speed (200 to 800 mm/s; default value: 500)
	Batt. max. speed	Adjustable speed (150 to 800 mm/s; default value: 200)
	First acceleration	Adjustable acceleration (300 to 900 mm/s) ² ; default value: 700
	Init. 1st decelerat.	Adjustable slowdown first initial position (25 to 75%)
	1st dec. final speed	Adjustable deceleration first final speed (200 to 400 mm/s; default value: 300)
	2nd dec. position	Adjustable slowdown second initial position (70 to 90%)
	2nd dec. final speed	Adjustable deceleration second final speed (100 to 200 mm/s; default value: 100)
	Final dec. pos.	Adjustable final slowdown start position (total distance - 100 to -20 mm)
	Approach speed	Adjustable speed (20 to 100 mm/s; default value: 50)
Reverse movem.	Fast rev. pos.	Adjustable position (0 to 60%)
	Slow rev. pos.	Adjustable position (60 to 100%)
Power	Closed Door	Value 0 to 5 (default value: 0)



Install. info.	
Service info.	
Installer	
Commis. date	
Serial number	
HW version	
SW version	

Info. Operation	
Number of cycles	
Total working time	
Last maint. cyc.	
Total warnings	
Last maint. warn.	
Motor temp.	
Driver temp.	
Last maintenance	
Sensor status	<ul style="list-style-type: none"> • Inside radar • Outside radar • Inside photo. • Outside photo. • Safety sensor 1 • Safety sensor 2 • KB • KC • Electrolock



Maintenance	
Next maintenance	Definition of the time interval to display the maintenance required Warning.
Autochecking	Records the date maintenance was carried out on. Disables the Maintenance required Warning.

Access code	
Code change	Changes the access code for the Technical Menu.
Reset code	Resets the code to 00000.
Code activation - Disabled (default value) - Enabled	Enables/disables code protection for access to the technical menu.

Indicators on the digital selector display

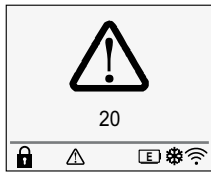





The following indicator icons may be displayed, as well as the messages shown on the digital selector screen:

- 1 Warning indicator in the centre of the screen with the Warning code:



- 2 Winter mode/partial opening indicator at the lower right edge .

- 3 Selector locked indicator (keys are disabled) in the lower right corner: .

- 4 Indicator for the selected battery system operating mode: , , . Emergency operating mode will be selected by default (EN 16005): .

- 5 CONNECT signal coverage indicator () (only if CONNECT device is connected).



5 WARNINGS / ERRORS

During operation, the operator performs self-diagnosis of the machine's main components and monitors the various peripherals connected to the circuit board. To this end, if there is a Warning or Error Code during operation, the digital selector's screen shows this by indicating the specific Warning Code.

In the event of a Warning or Error, the operator will run a self-diagnosis. If the cause of the Warning or Error has been rectified, the operator will try to automatically restore the operation.

This is the list of Warning Codes that can be automatically detected by the operator:

Type of Warning	Description	Possible cause	Possible solution
Warning 01	Setup incomplete	The setup operation has not been completed	The Setup operation must be performed from the digital selector.
Warning 02	Obstruction	The motor may be locked or the encoder damaged	Check whether the motor is locked; if it is not, ensure that the cable is not damaged and it is connected properly.
Warning 03	Electrolock failure	The electrolock cannot be released	Check whether the electrolock can be released manually. If it operates correctly, check the electrolock configuration and test configuration.
Warning 04	Flash memory failure	The flash memory is damaged or outdated	Perform a "restore default parameters" if the Warning remains. Contact technical support, as the electronic board may need replacing.
Warning 05	Motor controller temperature	The transistors controlling the motor are overheating.	The motor will remain disengaged until the temperature returns to the correct operating range, at which point the door will resume normal operation. A door Reset can help ensure a quicker recovery.
Warning 06	Motor overcurrent	There is overcurrent at the motor input.	Check if the motor is locked; if it is disengaged, perform a Reset. Contact technical support if the Warning persists after the Reset, as the electronic board may need replacing.
Warning 07	Motor temperature	The motor is overheated	The motor will remain disengaged until the temperature returns to the correct operating range, at which point the door will resume normal operation. A door Reset can help ensure a quicker recovery.
Warning 08	Photocell 1 (interior) active	Obstacle in the photocell detection area	Check if there are any obstacles in the detection area. If so, remove them. If not, check the configuration and correct operation of the sensor. A door Reset can help ensure a quicker recovery.
Warning 09	Photocell 2 (exterior) active	Obstacle in the photocell detection area	Check if there are any obstacles in the detection area. If so, remove them. If not, check the configuration and correct operation of the sensor. A door Reset can help ensure a quicker recovery.
Warning 10	Inside radar active	Obstacle in the activation radar detection area	Check if there are any obstacles in the detection area. If so, remove them. If not, check the configuration and correct operation of the sensor. A door Reset can help ensure a quicker recovery.
Warning 11	Outside radar active	Obstacle in the activation radar detection area	Check if there are any obstacles in the detection area. If so, remove them. If not, check the configuration and correct operation of the sensor. A door Reset can help ensure a quicker recovery.



Type of Warning	Description	Possible cause	Possible solution
Warning 12	Safety sensor 1 (left) enabled	Obstacle in the safety sensor detection area	Check if there are any obstacles in the detection area. If so, remove them. If not, check the configuration and correct operation of the sensor. A door Reset can help ensure a quicker recovery.
Warning 13	Safety sensor 2 (right) enabled	Obstacle in the safety sensor detection area	Check if there are any obstacles in the detection area. If so, remove them. If not, check the configuration and correct operation of the sensor. A door Reset can help ensure a quicker recovery.
Warning 14	24 V internal power supply failure	One of the internal board voltages is out of the correct operating range	Perform a Reset to restore the correct functioning of the board. Contact technical support if the Warning persists, as the electronic board may need replacing.
Warning 15	Motor voltage failure	The motor voltage is out of range	Perform a Reset to restore the correct functioning of the board. Contact technical support if the Warning persists, as the electronic board may need replacing.
Warning 16	Power supply relay failure	Board power fuse failed	Change the board's power fuse: F2 SMD 10A
Warning 17	Main voltage failure	Incorrect power supply voltage level	Check whether the input voltage is correct. If correct, check the power supply fuse. If both are correct, contact technical support, as it may be necessary to replace the circuit board or power supply.
Warning 18	System voltage failure	Incorrect system voltage level	Perform a Reset to restore the correct functioning of the board. Contact technical support if the Warning persists, as the electronic board may need replacing.
Warning 19	Atmospheric temperature	The ambient temperature is outside the suitable range	The motor will be released while the temperature is outside the correct range. The door will automatically return to normal operation when the temperature returns to normal. The maximum temperature reached can also be checked via the digital selector. The range can also be adjusted using the selector.
Warning 20	Trapment	There has been a trapment	Remove the obstacle or check for any friction in the door's movement.
Warning 21	Battery damaged	The battery has no voltage or is not connected	Check that the battery is connected. If the battery is damaged, replace it.
Warning 22	Battery flat	The battery does not have sufficient charge	Allow the battery to charge. A Setup can be performed to remeasure the charge every 24 hours.
Warning 23	Emergency	The emergency signal is active	Depending on the signal configuration, the Warning disappears automatically when the signal is deactivated, or a Reset will be required to clear the Warning.
Warning 24	Continuous trapment	There have been 3 consecutive trapments	Remove the obstacle or check for any friction in the door's movement. A Reset will be required to restore proper door operation.
Warning 25	Photocell 1 test failure (interior)	Photocell test not correctly configured or cables connected incorrectly	Check if the photocell configuration matches the configuration in the digital selector. If correct, contact technical support as the photocell may need replacing. The Normally Closed without test configuration can be temporarily used.



Type of Warning	Description	Possible cause	Possible solution
Warning 26	Photocell 2 test failure (exterior)	Photocell test not correctly configured or cables connected incorrectly	Check if the photocell configuration matches the configuration in the digital selector. If correct, contact technical support as the photocell may need replacing. The Normally Closed without test configuration can be temporarily used.
Warning 27	Safety sensor 1 test failure (left)	Safety sensor test not correctly configured or cables connected incorrectly	Check if the sensor configuration matches the configuration in the digital selector. If correct, contact technical support as the sensor may need replacing. The Normally Closed without test configuration can be temporarily used.
Warning 28	Safety sensor 2 test failure (right)	Safety sensor test not correctly configured or cables connected incorrectly	Check if the sensor configuration matches the configuration in the digital selector. If correct, contact technical support as the sensor may need replacing. The Normally Closed without test configuration can be temporarily used.
Warning 29	Panic breakout	The leaves of the fitting are closed	Interlock the leaves in their position
Warning 30	K1 relay failure (motor)	The relay or electronic board is damaged	Check if the motor is connected, then carry out a Reset to repeat the test. Contact technical support if the Warning persists, as the electronic board or the motor may need replacing.
Warning 31	K2 relay failure (power)	The relay is damaged	Turn the electronic board off and on. Check if the relay can switch. Contact technical support if the Warning persists, as the electronic board may need replacing.
Warning 32	K3 relay failure (motor bus)	The relay is damaged	Turn the electronic board off and on. Check if the relay can switch. Contact technical support if the Warning persists, as the electronic board may need replacing.
Warning 34 (*)	Communication failure with expansion board	There is a communication failure with the input/output expansion board	Check if the communication cable is installed correctly. Performing a Reset may help recover from the error. If the problem persists, check the configuration of the expansion board.
Warning 35	Reset incomplete	The operator cannot complete the Reset process	Check if the door is blocked by any device or obstacle.



(*): This Warning can only be activated if an expansion board is connected and the circuit board is compatible with the expansion board.

1 MAINTENANCE

Automatic door installations require regular maintenance, with regularity determined by environmental conditions and traffic density.

- Check that all the fastening screws are tight.
 - Clean and lubricate all sliding and moving components.
 - Examine the cable connections.
 - Check that the arm's fastening screw is tight.
 - Check that the leaf is stable and that the movement is fluid and frictionless from "door open" position to "door closed" position.
 - Check that the speed, times and safety functions are selected correctly.
- Check that the activation sensors and safety sensors work correctly.
 - In the absence of power, check that the door closes again with the spring at controlled speed without any danger.

▲ Remove the main power line before starting operations on the operator.

▲ Any component that is damaged or worn must be replaced! Use only original spare parts. First check ERREKA's catalogue.

2 WARRANTY

ERREKA CONNECTED ACCESS declares, under its sole responsibility, that the products supplied have a warranty lasting 12 months from the date of purchase (or date of delivery protocol). This warranty applies to any manufacturing defect and will include the cost of transporting the material to the closest approved technical service.

The installer is responsible for delivering the equipment to the technical service.

This warranty does not include:

- Damage caused by incorrect installation or use of the unit.
- Damage caused by any handling by unauthorised persons.
- Damage caused by external or atmospheric agents (lightning, flooding, etc.).
- Normal wear and tear from regular use of the product.





ERREKA GROUP
B° Ibarreta s/n
20577 Antzuola (Gipuzkoa) Spain
T. (+34) 943786009
info@erreka.com
www.erreka.com

ERREKA CONNECTED ACCESS
Polig. Ind. San Juan,
B. San Juan, 93
20570 Bergara (Gipuzkoa) Spain
T. (+34) 943769900