

THERM 40



SLIDING
DOORS

PROFILE

Thermal Break Profile



The Therm40 profile model is designed to insulate the building from outside heat and cold without compromising aesthetics.

Thermal transmittance (U_d is measured in W/m^2K or $W/m^2°C$) reflects a building element's ability to transmit heat of a constructive element. A lower U-value indicates better insulation due to reduced energy transfer between the two faces of the building element. The insulation level of a sliding door depends on the insulation level of the profile and of the glass.

In the case of THERM40 profiles, two metal sections are joined by a non-metal component for thermal insulation.

To obtain an optimum level of insulation for the automatic door, it is necessary to use insulating glass, known under the names of chamber glass or double glazing, whose low coefficient of thermal transmission (U_g) translates into high thermal insulation.

HIGH ENERGY EFFICIENCY

Thermal transmittance values: $<1,22 W/m^2K^*$

NARROW AND COMPACT DESIGN

FOR SLIDING DOORS

compatible with Erreka operators

*Value for a door configuration 2+2 of 6x3m with $U_g=0,6W (m^2K)$

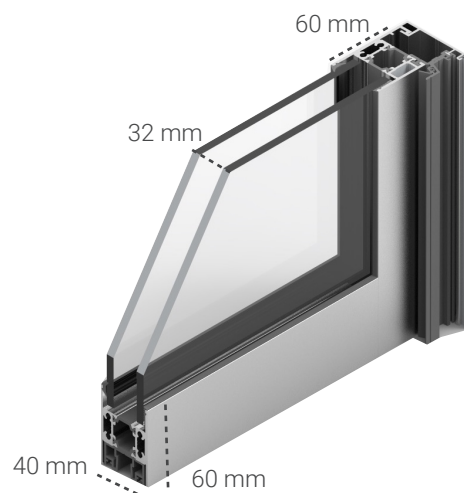

THERM 40

PROFILES

TECHNICAL CHARACTERISTICS

Thermal transmittance rate	Ud=1.6W (m ² K) Ug=1.1W (m ² K) Ud=1.22W (m ² K) Ug=0.6W (m ² K) *Value for a 2+2 door configuration of 6x3 m. Ud=U Total Ug=U Glass
Face width	60 mm
Base height	60 mm
Profile depth	40 mm
Glass thickness	32 mm
Safety distance	EN 16005
Standards:	EN 16361, EN 16005, EN ISO 10077-2

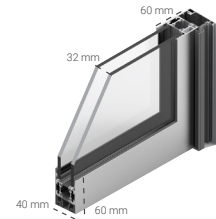

CHARACTERISTICS	DOUBLE SLIDING DOOR	SINGLE SLIDING DOOR	
Free passage	1.000 - 3.000mm	750 - 2.000mm	
Maximum free passage height	3.000mm	3.000mm	
MAXIMUM WEIGHT PER LEAF			
Operator	Ertain4	2 x 100 kg	1 x 140 kg
	Global4	2 x 140 kg	1 x 200 kg

Therm 40 profiles are fitted with:

AW-6060 T6 extruded aluminium alloy profiles

EN AW6060 primary aluminium alloy conforms to Standard UNE EN573-3. 6060 aluminium alloy is widely used for architectural profiles. Optimal for anodising, therefore providing extra protection if necessary, along with a very good decorative finish

Thermal break profile with polyamide rods reinforced with glass fibre

Coextruded PVC and EPDM seals

EASY ASSEMBLY SOLUTION

comprising of 3 profiles, a lintel and a recessed guide.

COMPATIBLE OPERATORS: ERTAIN 4 AND GLOBAL 4

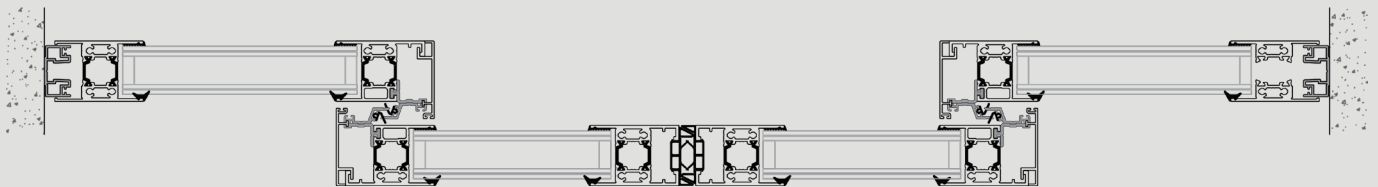

Cross-section of sliding door in 2+2 configuration

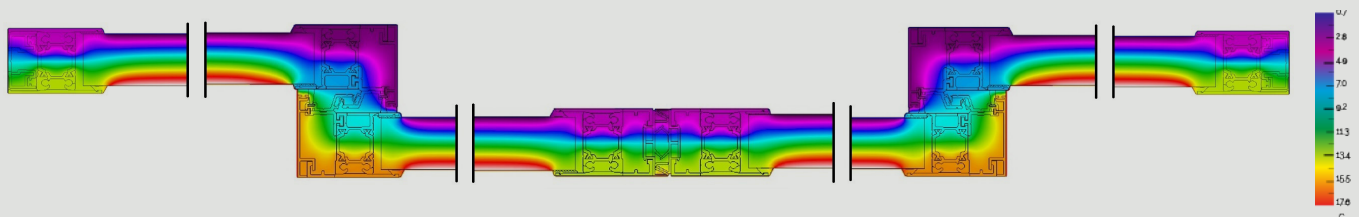

Heat map of thermal transmittance calculation details

THERM 40

PROFILES

AVAILABLE ACCESSORIES

LINTEL THERM40

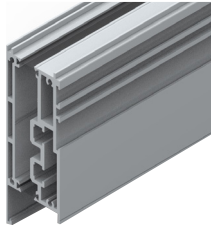

RECESSED GUIDE

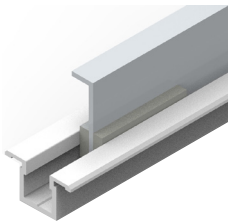

SURFACE GUIDE (OPTIONAL)

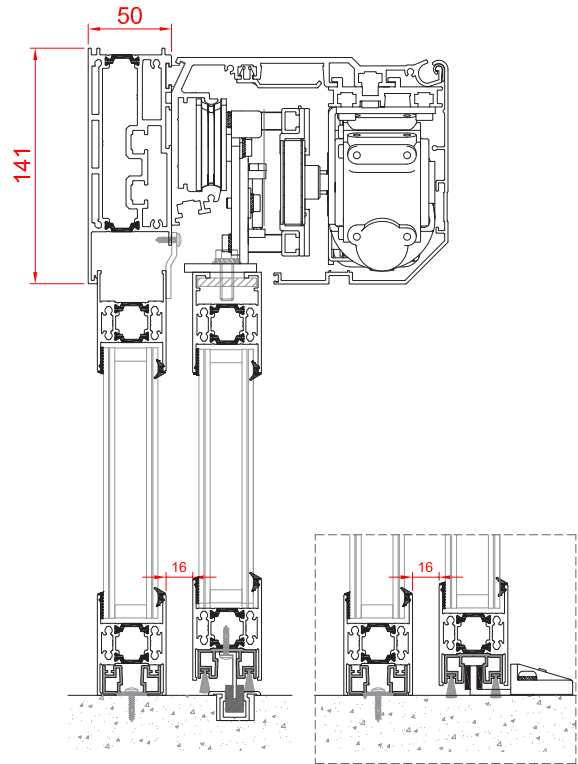
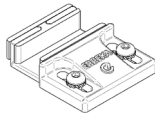

THERM 40 MULTILOCK

HIGH ENERGY EFFICIENCY AND SECURITY.

The automatic door can be locked and unlocked quickly and securely by adding a hook and bolt lock with built-in European cylinder to the Therm40 profile.

