

This quick guide is a summary of the complete installation manual. The manual contains safety warnings and other explanations which must be taken into account. The most recent version of this guide and the installation manual are available at the "Downloads" section on Erreka's website: <http://www.erreka.com>

WARNING

The options and functions described in this guide apply for the firmware version indicated on the circuit. The firmware, as part of a process of continuous improvement, is subject to new functionalities or upgrades being included as a result of new versions which are not necessarily compatible with previous ones. For this reason, some options or functions may differ or be unavailable if your firmware is older than shown in this guide.

Elements of the complete installation

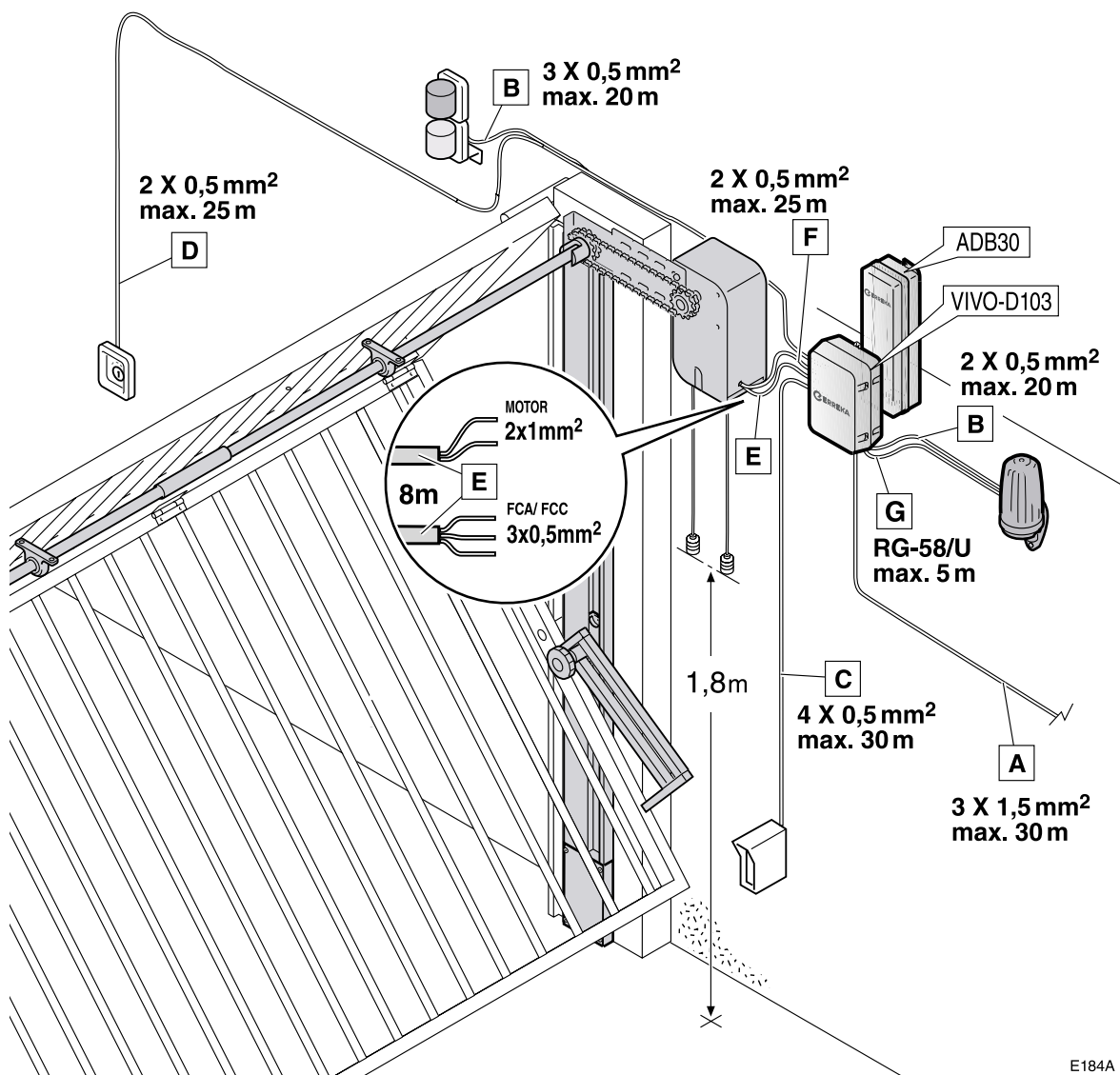

Electrical wiring

- A: Main power supply
- B/G: Flashing light with antenna
- C: Photocells (mirror)
- D: Pushbutton or key switch
- E: Operator (motor + limit switches)
- F: Operator release

General connections

R.E. Plug-in receiver. It is possible to use a two channel Roller receiver, such as the IRRE2-250. The first channel acts on ST1 and the second on ST2.

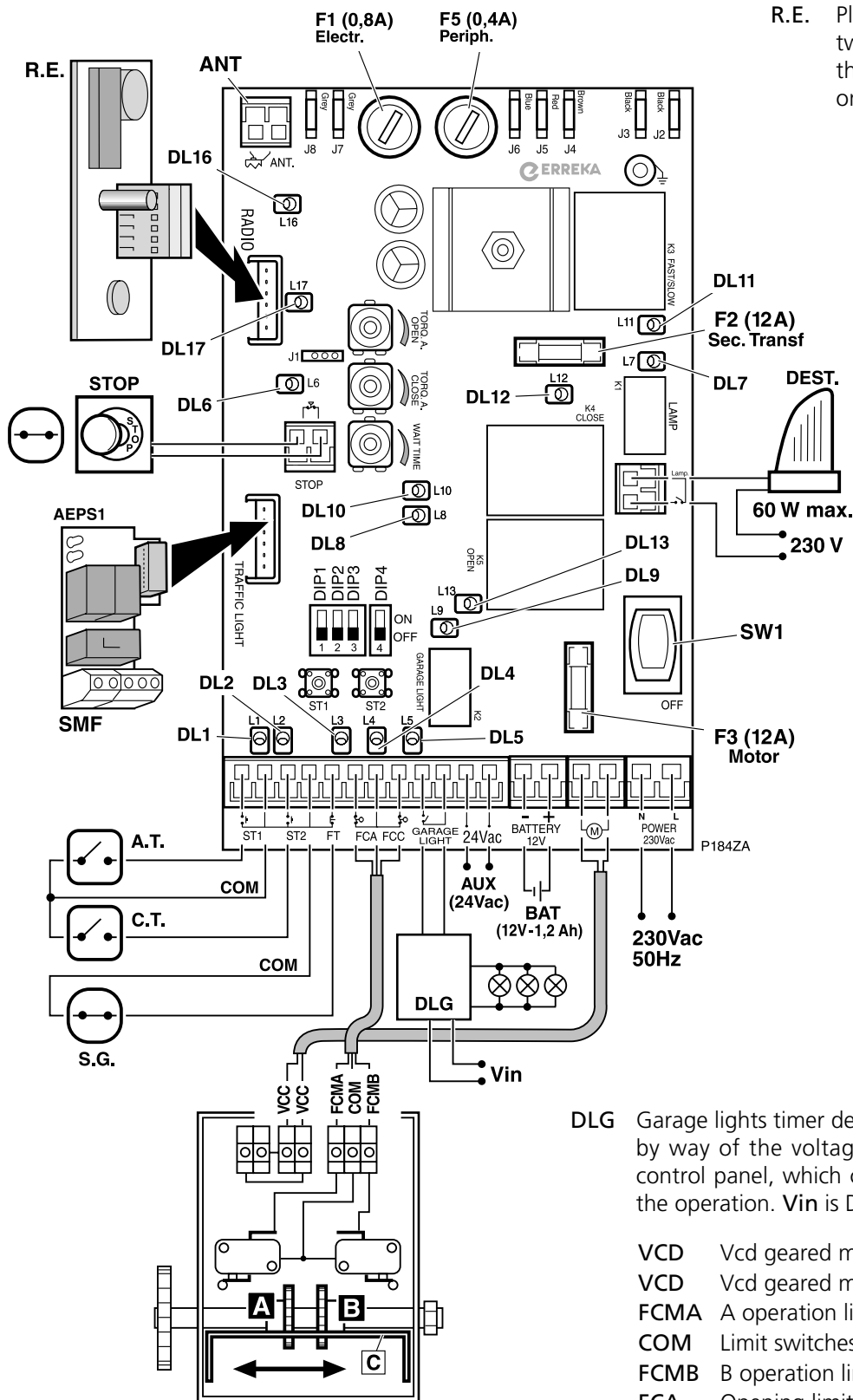

LEDs and fuses:

- SW1 General power switch
- F1 Electronic fuse (0.8A)
- F2 Transformer secondary fuse (12A)
- F3 Motor fuse (12A)
- F5 Peripheral fuse (0.4A)
- DL1 ST1 Opening and closing key signal (NA)
- DL2 ST2 Closing key signal (NA)
- DL3 Photocell signal (NC)
- DL4 Opening limit switch signal (NC)
- DL5 Closing limit switch signal (NC)
- DL6 STOP signal (NC)
- DL7 Flashing light relay
- DL8 Door open
- DL9 Garage light relay
- DL10 Stop due to obstacle
- DL11 Fast/slow operation relay
- DL12 Closing relay
- DL13 Opening relay
- DL16 230V Power supply
- DL17 Microcontroller supply

DLG Garage lights timer device. The device is activated by way of the voltage-free contact (NA) in the control panel, which closes briefly at the start of the operation. Vin is DLG power supply.

- VCD Vcd geared motor connection
- VCD Vcd geared motor connection
- FCMA A operation limit switch connection
- COM Limit switches common connection
- FCMB B operation limit switch connection
- FCA Opening limit switch connection
- FCC Closing limit switch connection

Adjust the limit switches by turning wheels **A** and **B**, having previously removed the guide **C**.

Check turning direction using the mini-pushbuttons ST1 (open) and ST2 (close), having first placed DIP1, DIP2 and DIP3 in OFF. If the turning direction is not correct, interchange the cables connected to the cable connectors (M)(VCC).

Ensure the limit switches are correctly connected for opening and closing. Carry out the check using the mini-pushbuttons ST1 (open) and ST2 (close), having previously placed DIP1, DIP2 and DIP3 in OFF.

SW2 functions during programming (DIP3 = ON)

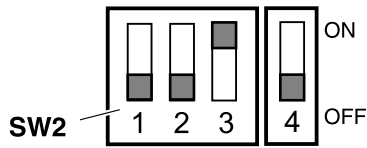

F184AA

DIP3=ON: programming enabled

DIP3 must be in ON in order to carry out programming. The position of the other DIPs is indifferent.

Total travel programming

☞ Before starting programming, ensure the limit switches are correctly adjusted.

☞ **Operator thrust is regulated using the PM.A (opening) and PM.C (closing) potentiometers, as described on the following page, which can be done during programming or during operation. This regulation is valid both for programming and for operation, i.e. the operator is also sensitive during programming** and can therefore detect obstacles and come to a stop. When the following key command is received, reverse operation will take place at slow speed through to the limit switch for the previous operation, remaining on standby for reprogramming.

1 Place DIP1, DIP2, DIP3 and DIP4 in OFF and connect the power supply.

2 Close the gate by keeping ST2 pressed down, through to the closing limit switch (FCC).

3 Place DIP3 in ON.

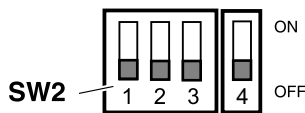

G184AA

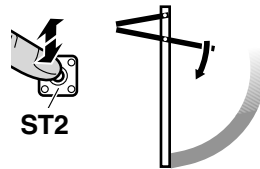

G184B

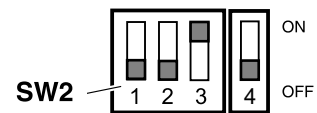

G184DA

4 Press ST1 to start opening the gate at slow speed.

5 Press ST1 to start fast opening.

6 Press ST1 to start slowdown in opening.

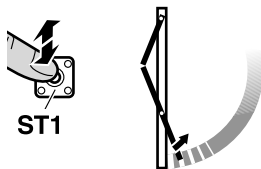

G184E

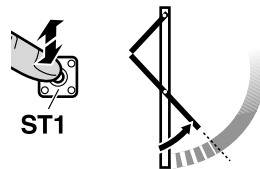

G184F

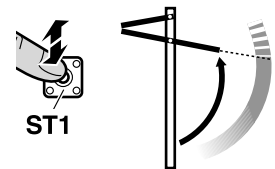

G184G

7 Opening finishes when the opening limit switch is reached (FCA).

8 Press ST1 to start closing the gate at slow speed.

9 Press ST1 to start fast closing.

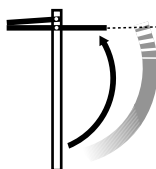

G184H

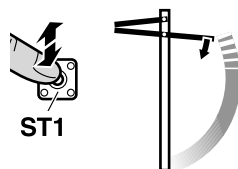

G184I

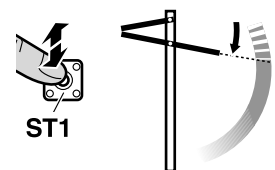

G184J

10 Press ST1 to start slowdown in closing.

11 Closing finishes automatically when the closing limit switch is reached (FCC).

12 Place DIP3 in OFF.

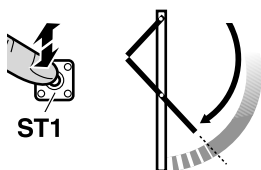

G184K

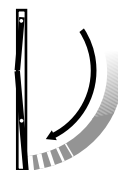



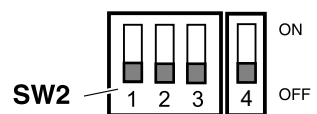

G184L

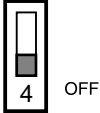

G184AA

i Photocell shade function: when the photocell shadow function is activated, the photocell is invalidated in the last part of the closing run. To do this, the control panel detects the position in which the leaf activates the photocell whilst programming the closing run, and takes it as a reference for invalidation during operations (invalidation comes about a moment before the point detected during programming).

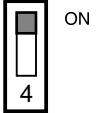
Selecting operation modes with SW2 (DIP3 = OFF)

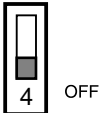
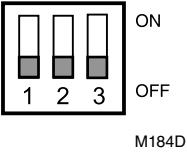
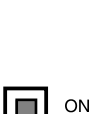
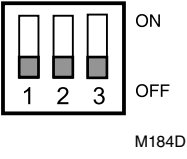
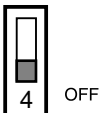
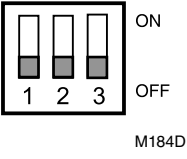
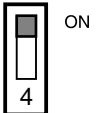
DIP1, DIP2, DIP3	Operation mode	DIP4
 <p>M184B</p>	<p>Automatic mode (the gate closes automatically after standby) with collective opening (during opening, the gate CANNOT be stopped by sending a key command).</p> <p>During closing, ST1 produces stopping and reverse movement.</p> <p>The photocell shadow function is activated.</p>	 <p>ST1 active: with the gate open, pressing ST1 resets standby.</p>
 <p>M184A</p>	<p>Automatic mode (the gate closes automatically after standby) with collective opening (during opening, the gate CANNOT be stopped by sending a key command) and optional automatic closing (with the gate open, the gate closes by pressing a key command).</p> <p>During closing, ST1 produces stopping and reverse movement.</p> <p>The photocell shadow function is activated.</p>	 <p>ST1 and ST2 active: with the gate open, pressing ST1 resets standby, whilst pressing ST2 cancels standby and closes the gate.</p>
 <p>M184C</p>	<p>Step-by-step mode (the gate only closes by sending a key command) with alternative stop (during opening, the gate can be stopped by pressing ST1).</p> <p>During closing, ST1 produces stopping and reverse movement.</p> <p>The photocell shadow function is enabled but only works if the opening operation is completed. For this reason, if a close command is sent during opening or alternative stop, opening is carried out (DIP4=OFF) or it is ignored (DIP4=ON).</p>	 <p>ST1 active: during alternative stop, pressing ST1 closes the door (if the photocell shadow function is enabled, pressing ST1 opens the door).</p>
 <p>M184D</p>	<p>Dead-man mode</p>	 <p>ST1 and ST2 active: during opening, the door stops and closes by pressing ST2 (if the photocell shadow function is enabled, ST2 does not have any effect).</p> <p>During alternative stop, pressing ST1 continues opening whilst pressing ST2 brings about closing (if the photocell shadow function is enabled, ST2 does not have any effect).</p> <p>During standby, the gate closes by pressing ST2.</p>
 <p>M184D</p>	<p>Dead-man mode</p>	 <p>HPAC (Dead-man mode in opening and closing): the gate opens by keeping ST1 pressed down and closes by keeping ST2 pressed down.</p>
 <p>M184D</p>	<p>Dead-man mode</p>	 <p>HPC (Dead man mode in closing): the gate is opened by briefly pressing ST1 (step-by-step opening, with alternative stop by pressing ST1) and is closed by keeping ST2 pressed down.</p>

Setting the jumpers and potentiometers

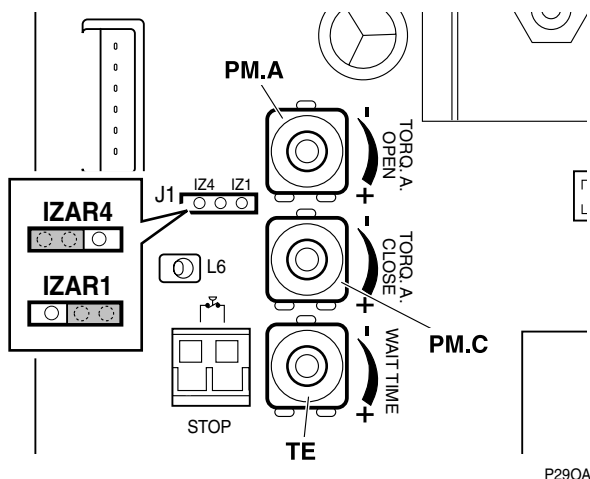

J1 Operator model jumper (IZAR1-IZAR4)

▲ **J1 must be placed in the position corresponding to the operator installed (IZAR1 or IZAR4). Failure to do so may lead to accidents.**

PM.A Torque adjustment (maximum thrust) in opening

PM.C Torque adjustment (maximum thrust) in closing

▲ **Adjust the torque to respect the maximum closing thrusts set out in Standard EN12453:2000. Make the measurements as described in Standard EN 12445:2000.**

TE Open gate standby adjustment (only works in automatic mode, DIP1=ON)