

# ERREKA

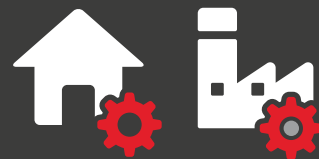

RESIDENTIAL  
/ INDUSTRIAL



Intense use  
Powerful  
High performance  
Multiple versions

## VULCAN

HYDRAULIC OPERATOR  
FOR SWING GATES

we open  
the gates for you

[www.erreka-automation.com](http://www.erreka-automation.com)



# VULCAN

## HYDRAULIC OPERATOR FOR SWING GATES



**Intensive use** for condominium access  
**Smooth** opening and closing slow down  
**Self locking**, non locking in different versions  
**Powerful** and high resistant  
**Practical** plug-in cable connector  
**Anti-vibration/silent** - Fast versions  
**Anodized aluminium** finishing

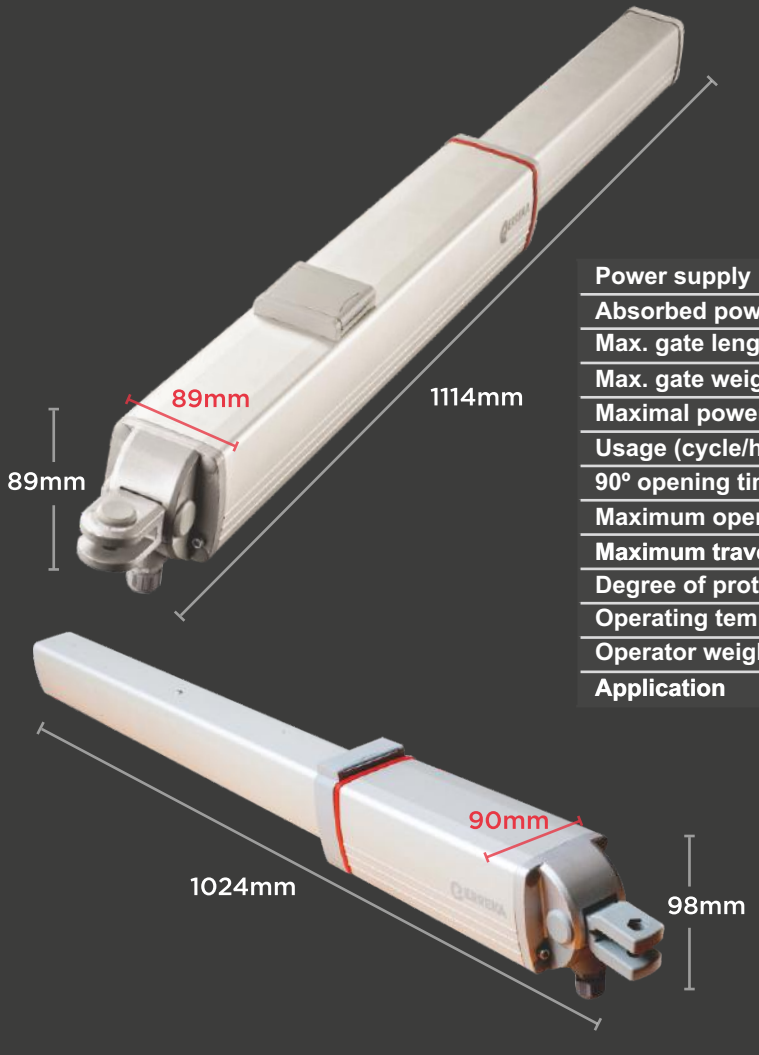

### TECHNICAL FEATURES:

	VUA13RFLB	VUA33FLB	VUA33RFLB	VUA43FLB	VUA43RFLB
Power supply	220/50-60				
Absorbed power (W)	160		230		
Max. gate length (m)	2.5	4.0	3.0	6.0	4.5
Max. gate weight (kg)	250	400	400	500	450
Maximal power (N)	3000		7000		
Usage (cycle/h)	45		60		
90° opening time (s)	10	24	12	34	17
Maximum opening angle (°)	110°				
Maximum travel (mm)	265		400		
Degree of protection (IP)	65				
Operating temperature (°C)	-35/+90				
Operator weight (kg)	7.5	9.5		11	
Application	Residential and industrial				

### RECOMMENDED ACCESSORIES

#### Control board

- VIVO-M101 (1 motor)
- VIVO-M201 (2 motors)
- VIVO-M203

#### Receiver

- IRRE2-250
- IRIN2S-250

#### Transmitter

- LUNA
- IRIS
- LIRA



#### Flashing lamp

#### Photocells

#### Electric lock

#### Batteries



### COMPLETE INSTALLATION

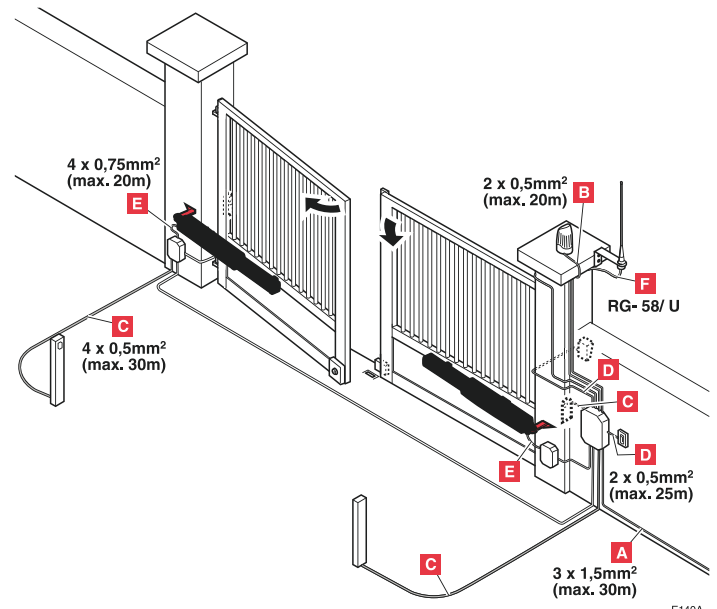

#### ELECTRICAL CONNECTIONS

- A: Power supply
- B: Flashing lamp
- C: Photocells
- D: Push button / key switch
- E: Motor
- F: Antenne

E140A