

# SLIM20



## PROFILE

### Framed Doors

---



SLIDING  
DOORS



#### **Slimline design with a sleek aesthetic finish.**

SLIM20 model has been designed in accordance with the safety standards EN16005, EN16361 (safety distances).

It is a 20 mm wide framed profile that allows the installation of glass with a maximum width of 12 mm.

At the same time, its design gives entrances a modern and functional appearance, without any loss of strength.

This is a suitable model for entrances where it is necessary to maintain medium levels of airtightness while keeping a clear view of the interior with glass being the main element.

The assembly of the frames at 90° is carried out on an end-to-end joint, with sheet metal screws on a reinforcement wedge.

Side U-profiles are included to mitigate any slams or wall imperfections.

#### **STRAIGHTFORWARD INSTALLATION**

---

#### **EASY ASSEMBLY**

---

#### **SUITABLE FOR THE OPERATORS ERTAIN, GLOBAL AND TELESCOPIC**

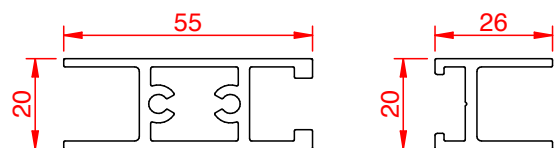

# SLIM20

## PROFILE

### TECHNICAL FEATURES

	SLIM20
Dimensions: Depth (D) x Height (H)	Horizontal profile 20 mm x 55 mm
	Vertical profile 20 mm x 26 mm
Material	aluminium
Standard colour	silver*
Max. door leaf size	2500 mm / 120 kg
Leaf width	Min. 500 mm - Max.1500 mm
Glass fastening	framed profile
Fastening to carrier	fastening nuts and adjustable carrier bracket
Glass thickness	10 mm - 12 mm
Mechanical manual lock	Optional floor lock ZSEG7

### ACCESSORIES

#### TYPES OF FLOOR GUIDES

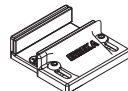
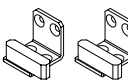
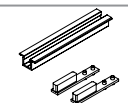
GUIA01	Outer floor guide		It is suitable for linear sliding doors.
KIT GUIA 2+1 S	Inner floor guide (set of 2)		It is suitable for linear and telescopic sliding doors.
KIT EMPOTRAR	Underground guide (set)		It is suitable for linear and telescopic sliding doors. Two fixing points for each moving leaf.

### INSTALLATION LAYOUT

