

ERGOS



CENTRAL MOTOR

Rolling Shutters

Electromechanical 230 Vac central motor for balanced rolling shutters up to 360 kg.

Easy external unlocking system by cable and cabinet.



RESIDENTIAL



INDUSTRIAL

**WIDE RANGE. LOCKED / NON LOCKED
MOTORS**

**ELECTROMECHANICAL LIMIT
SWITCHES**

**CHOICE OF DIAMETER SHUTTER SHAFT:
Ø60 MM AND Ø76MM**

**GREAT PUSHING FORCE WITH BIMOTOR
OPERATOR**

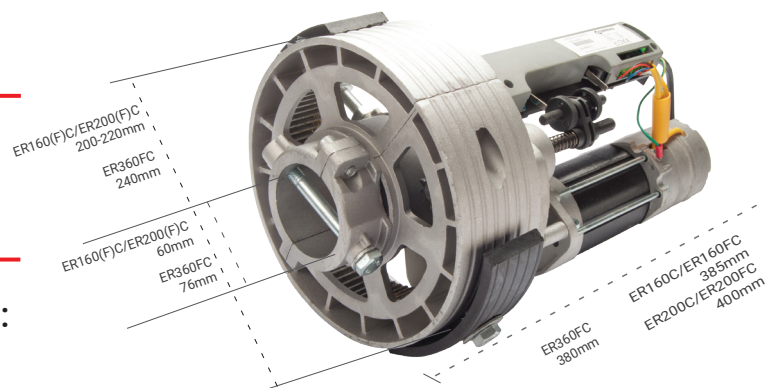

ERGOS

CENTRAL MOTOR

TECHNICAL CHARACTERISTICS

	ER160C/ ER160FC	ER200C/ ER200FC	ER360FC
Power supply (Vac/Hz)	230/50		
Power consumed (W)	600	750	1000
Absorbed current (A)	2,6	3,26	4,36
Capacitor (µF)	18	20	24
Available torque (Nm)	150	180	420
Output speed (rpm)	10		
Max. shutter weight (kg)	160	200	360
Max. shutter height (m)	6		
Duty cycle	S2>4min		
Lock	No/Yes	No/Yes	Yes
Limit switches	Yes		
Encoder	No		
Diameter shutter shaft (mm)	48/60		76
Diameter crowned drum (mm)	200/220		240
Protection level	IP20		
Operating temperature (°C)	-20/+60		
Packing dimensions (cm)	42x24x23		47x26x26
motor weight (kg)	8-9	9,5-10,5	15,1

RECOMMENDED KITS

	MOTOR		CONTROL PANEL		RECEIVER	REMOTE CONTROL	
	ER160FC (160 kg)	ER360FC (360 kg)	CLEVER01	WISE 01	IRRE2-250	IR02	KU02
ERGOS6	•		•		•	••	
ERGOS7		•	•		•	••	
ERGOS33	•			•			••
ERGOS34		•		•			••

INSTALLATION LAYOUT

