

IMPORTANT NOTE

This quick guide summarises the full installation manual. The full manual contains safety warnings and other explanations that must be taken into account. You can download the latest version of this guide and the installation manual in the "Downloads" section of the Erreka website: <http://www.erreka.com>.

The options and functions described in this guide are applicable from the *firmware* version indicated on the circuit. As part of a process of continuous improvement, the *firmware* is subject to the incorporation of new functionalities or their extension, and consequently to the generation of new versions not necessarily compatible with the previous ones. Therefore, if your *firmware* version is lower than the one indicated in this guide, some options and functions may not be available or may be different.

Elements of the complete installation

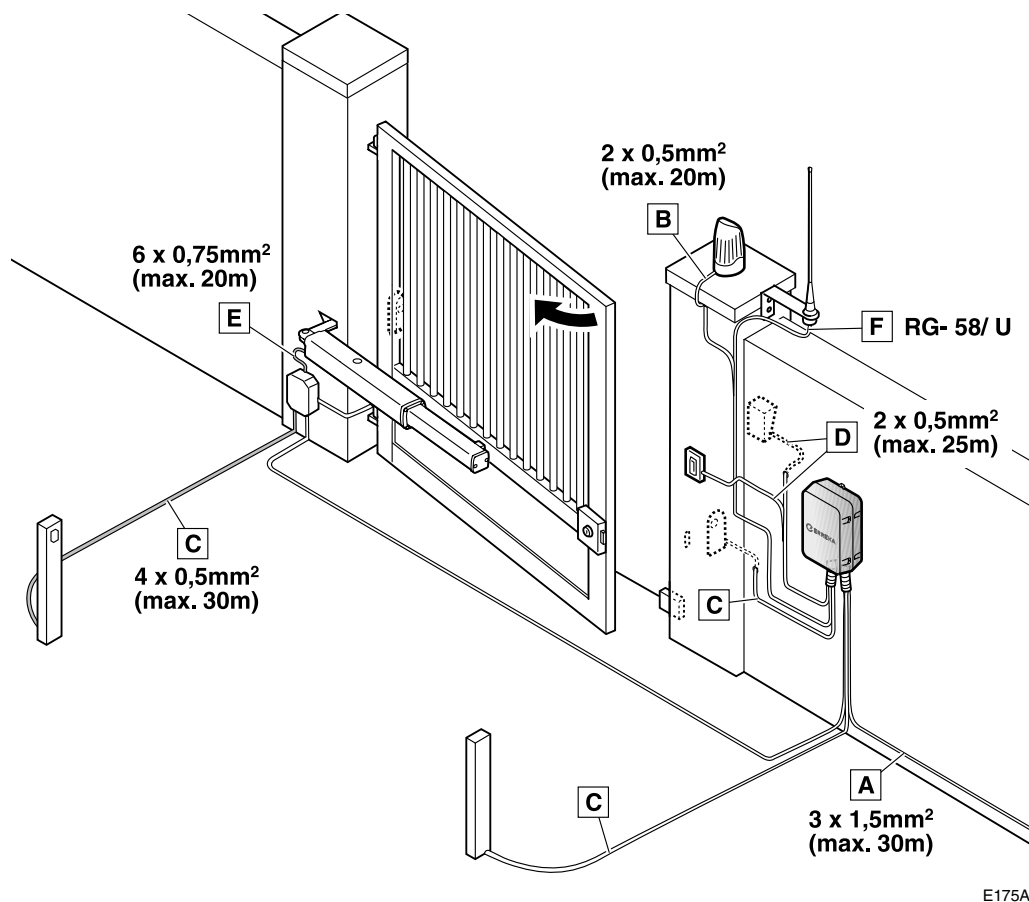

ELECTRICAL CABLING:

Element	N° wires x section	Maximum length
A: Main power supply	3x1.5mm ²	30m
B: Flashing light	2x0.5mm ²	20m
C: Photocells (Tx / Rx)	2x0.5mm ² / 4x0.5mm ²	30m
D: Pushbutton/wall key	2x0.5mm ²	25m
E: Operator / Limit switches	4x0.75mm ² / 4x0.50mm ²	20m
F: Antenna	Coaxial cable 50Ω (RG-58/U)	5m

General connections

PUL1: close mini-pushbutton
PUL2: open mini-pushbutton

Turning direction: check operation using the mini-pushbuttons PUL1 (close) and PUL2 (open). If the turning direction of the operator is not correct, interchange the cables connected in cable connectors G1 and G2.

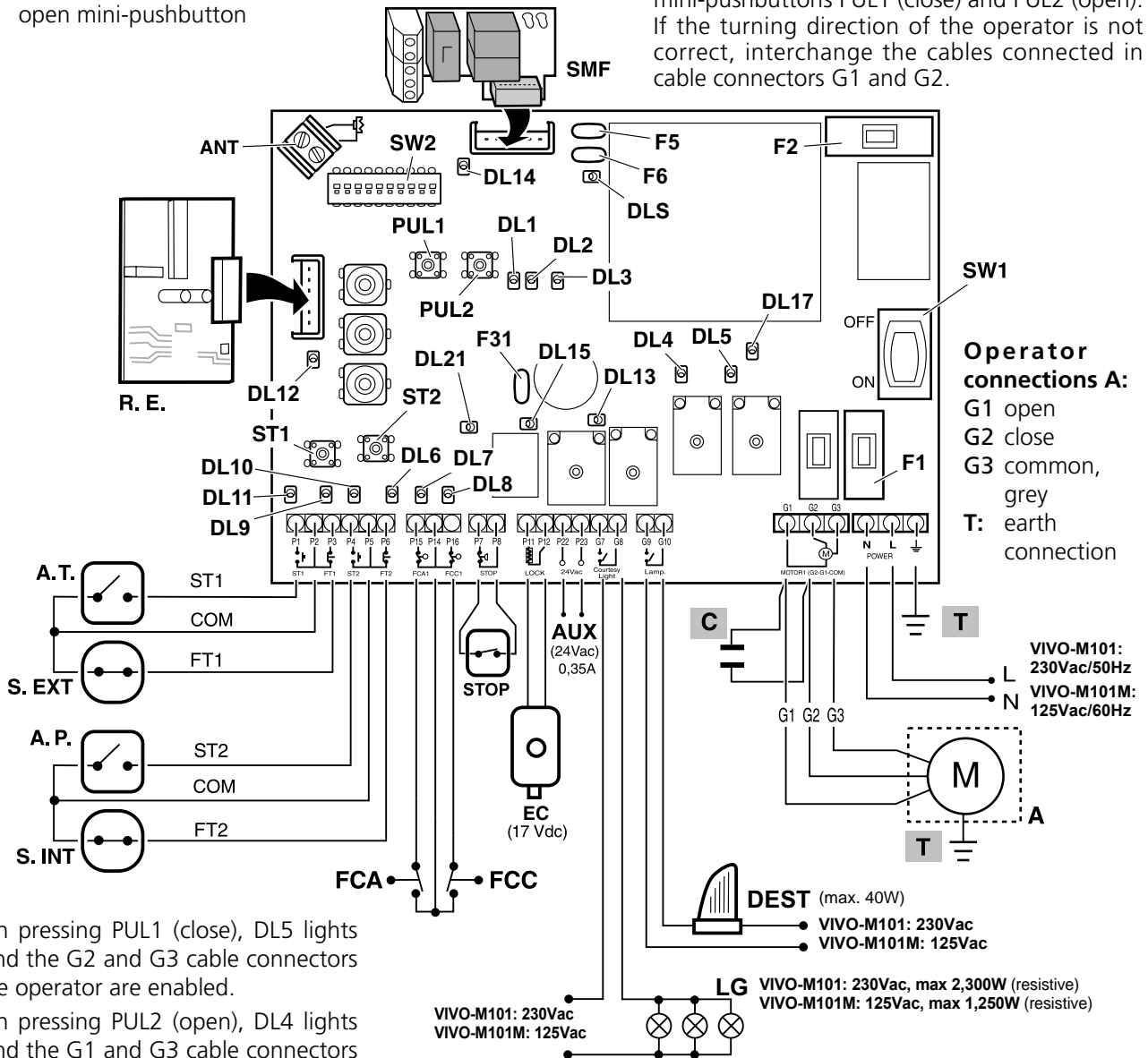

- When pressing PUL1 (close), DL5 lights up and the G2 and G3 cable connectors of the operator are enabled.
- When pressing PUL2 (open), DL4 lights up and the G1 and G3 cable connectors of the operator are enabled.

- DL1** Gate totally or partially open
- DL1 - DL3 flashing:** STOP contact open (emergency stop activated)
- DL2** Receiving RSD plug-in receiver radio signal (RUN/OK)
- DL3** Radio code or operation programming
- DL4** Opening relay activated
- DL5** Closing relay activated
- DL6** Interior safety device contacts (FT2) closed
- DL7** FCA contacts closed
- DL8** FCC contacts closed

- DL9** Exterior safety device contacts (FT1) closed
 - DL10** Pedestrian key command (ST2)
 - DL11** Total key command (ST1)
 - DL12** Plug-in receiver key command (except RSD)
 - DL13** Garage light relay activated
 - DL14** Power supply
 - DL15** Electrolock relay activated
 - DL17** Triac M1 activated
 - DL21** Settable fuse F31 LED**
 - DLS** Settable fuse F5, F6 LED**
- ** : DL ON: fuse closed;
 DL OFF: fuse open

Fuses:

- F1** M1 Motor fuse
 - M101: 2,5A (230Vac/50Hz)
 - M101M: 6,3A (125Vac/60Hz)
 - F2** Electronic fuse
 - M101: 0,5A (230Vac/50Hz)
 - M101M: 1A (125Vac/60Hz)
 - F31** 24Vac/350mA output settable* fuse;
 - F5, F6** Secondary settable* fuse
- *: resets automatically when overload ends

P17524

SW2 Functions during programming (DIP1=ON)

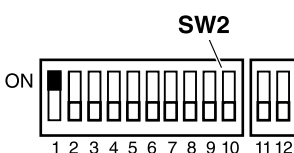

- DIP1=ON: programming enabled (DL3 lights up)
- DIP1=ON and DIP2=ON: total open/close programming
- DIP1=ON and DIP3=ON: pedestrian open/close programming
- DIP1=ON and DIP4=ON: total opening radio code programming
- DIP1=ON and DIP6=ON: pedestrian opening radio code programming

Using radio cards

This control board is factory set to use a two-channel receiver (e.g. IRRE2). This factory setting is modified if an RSD receiver is used and a permanent code is recorded (decoding through the board, DIP1 + DIP4 or DIP6 = ON). To restore the default configuration, insert the IRRE2 card, place DIP1 + DIP4 or DIP6 = ON and press the transmitter. Then return the DIPs to their previous position.

Total opening radio code programming (with RSD receiver only)

☞ If a receiver other than RSD is used, see the corresponding instructions.

1 Connect the electrical power supply and close the leaf, keeping PUL1 pressed down.

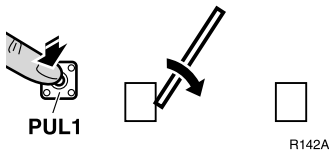

2 Select the code in the transmitter.

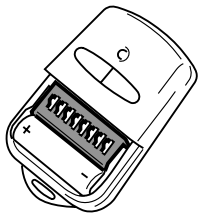

3 Place the DIPs as shown in the figure (DIP1=ON, DIP4=ON). DL3 lights up to show programming mode enabled.

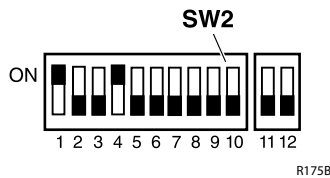

4 Press the button of the required channel. DL2 flashes to show programming is complete.

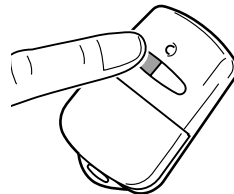

5 Place DIP1 and DIP4 in OFF. DL3 remains off.

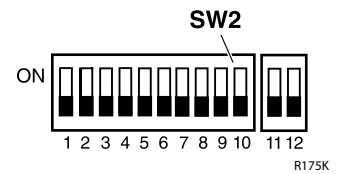

6 Disconnect and reconnect the electrical power supply.

Pedestrian opening radio code

Programming is carried out in the same way, using DIP6 instead of DIP4.

Total open/close programming

1 Connect the electrical power supply and close the leaf, keeping PUL1 pressed down.

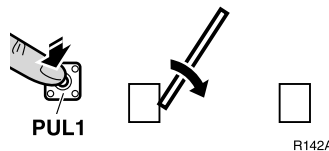

2 Place DIP1 in ON, DIP2 in ON, DIP5 in ON (only with electrolock), DIP8 in ON (soft stop)*.



DL3 lights up (programming enabled).

3 Press ST1 to start opening the leaf.

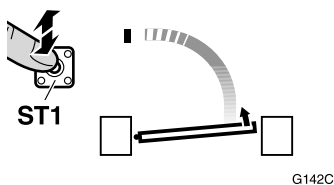

4 Press ST1 to start soft stop (with DIP8=ON only).

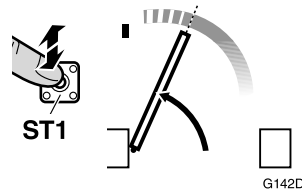

5 Press ST1 to finish opening; if the Opening Limit Switch (FCA) is installed, wait for the limit switch to finish opening.

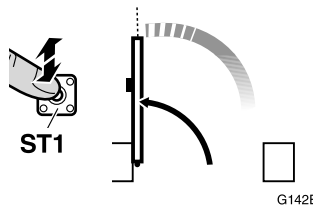

6 Press ST1 to start closing the leaf

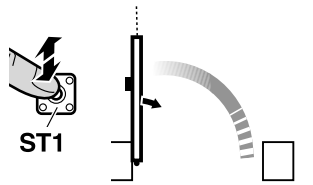

7 Press ST1 to start soft stop (with DIP8=ON only).

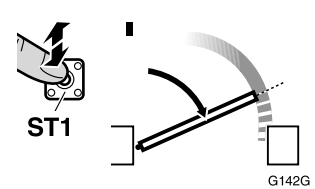

8 Press ST1 to finish closing; if the Closing Limit Switch (FCC) is installed, wait for the limit switch to finish closing.

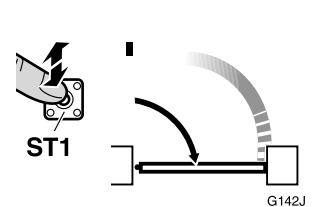

9 Place DIP1 and DIP2 in OFF. DL3 remains off.



*: If hydraulic operators with absorbers are used, soft stop is carried out mechanically by the operator (DIP8 = OFF)

Pedestrian open/close programming

This is carried out in the same way as total open/close programming, with the following differences:

- DIP1 and DIP3 are used instead of DIP1 and DIP2
- ST2 is used instead of ST1

Function and mode selection using SW2 (DIP1 = OFF)

DIP	Modes and functions	Option	Effect
DIP1		OFF	
DIP2	Advance warning	ON	the flashing light comes on and the operation begins after a 3 second warning
		OFF	the flashing light comes on and the operation begins immediately
DIP3	Opening mode	ON	step-by-step opening (the gate halts if a key device is enabled during opening, and closes if enabled again)
		OFF	collective opening (the control board does not obey the key commands during opening)
DIP4	Automatic or step-by-step mode (for pedestrian and total operation)	ON	automatic mode (the gate closes automatically after standby time has passed, which is adjusted using T.E.). Standby time restarts if the photocell is enabled.
		OFF	step-by-step mode (the gate only closes when receiving the key command)
DIP5	Reverse impulse / close impulse	ON	recede impulse enabled. If soft stop is selected (DIP8=ON), a close impulse is also carried out
		OFF	close and recede impulse disabled
DIP6	Automatic mode optional (only if DIP4 = ON)	ON	during standby, the gate obeys the key commands (can be closed before standby time finishes)
		OFF	the gate cannot be closed until standby time finishes; a key command will cause standby time to restart
DIP7	Maintaining hydraulic pressure (for hydraulic operators only)	ON	perform a closing and opening pulse (if the door remains open) every two hours, to maintain hydraulic pressure
		OFF	maintain pressure disabled
DIP8	Soft stop (only for operators without mechanical absorber)	ON	the leaves reduce their speed before reaching the stopper
		OFF	the leaves reach the stopper at high speed
DIP9	Anti-crushing function (obstacle detection); the obstacles are only detected when the gate has come to a complete halt.	ON	Function activated: during quick travel, the gate detects obstacles upon collision and recedes (when soft stop is activated, DIP8 = ON) or remains shut down (when soft stop is disabled, DIP8 = OFF) in order to prevent crushing
		OFF	Function disabled
DIP10	Dead man function Only with DIP4=OFF and DIP11=OFF	ON	Dead man function enabled (opening is done by keeping ST1 pressed down; closing is done by keeping ST2 pressed down)
		OFF	Dead man function disabled
DIP11	Interlock mode Only with DIP4=ON	ON	DIP10=ON: interlock mode with exterior and interior photocells DIP10=OFF: interlock mode with exterior photocell
		OFF	Interlock mode disabled
DIP12	Safety device	ON	VULCAN S safety device connected in the FCA cable connectors
		OFF	Device not connected

Potentiometer adjustment

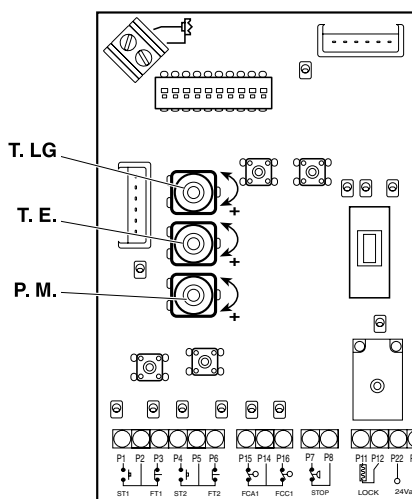

T.LG (garage light time): If the garage lighting circuit has been connected to the control board, set the time which the lights shall remain on using T.LG.

T.E. (gate open standby time): if automatic functioning mode has been programmed (DIP4=ON), set T.E. to adjust standby time with the gate open (before automatic closing begins).

P.M. (motor torque): use P.M. to adjust the maximum operator power value.

- Hydraulic operators: set P.M. at the maximum value.
- Electromechanical Actuators (anti-crushing function sensitivity): set P.M. at the minimum value possible, compatible with the proper operation of the gate.

▲ Adjust the torque to respect the maximum closing thrusts set out in Standard EN12453:2000. Make the measurements as described in Standard EN 12445:2000.