

IMPORTANT NOTE

This quick guide summarises the full installation manual. The full manual contains safety warnings and other explanations that must be taken into account. You can download the latest version of this guide and the installation manual in the "Downloads" section of the Erreka website: <http://www.erreka.com>.

The options and functions described in this guide are applicable from the *firmware* version indicated on the circuit. As part of a process of continuous improvement, the *firmware* is subject to the incorporation of new functionalities or their extension, and consequently to the generation of new versions not necessarily compatible with the previous ones. Therefore, if your *firmware* version is lower than the one indicated in this guide, some options and functions may not be available or may be different.

Elements of the complete installation

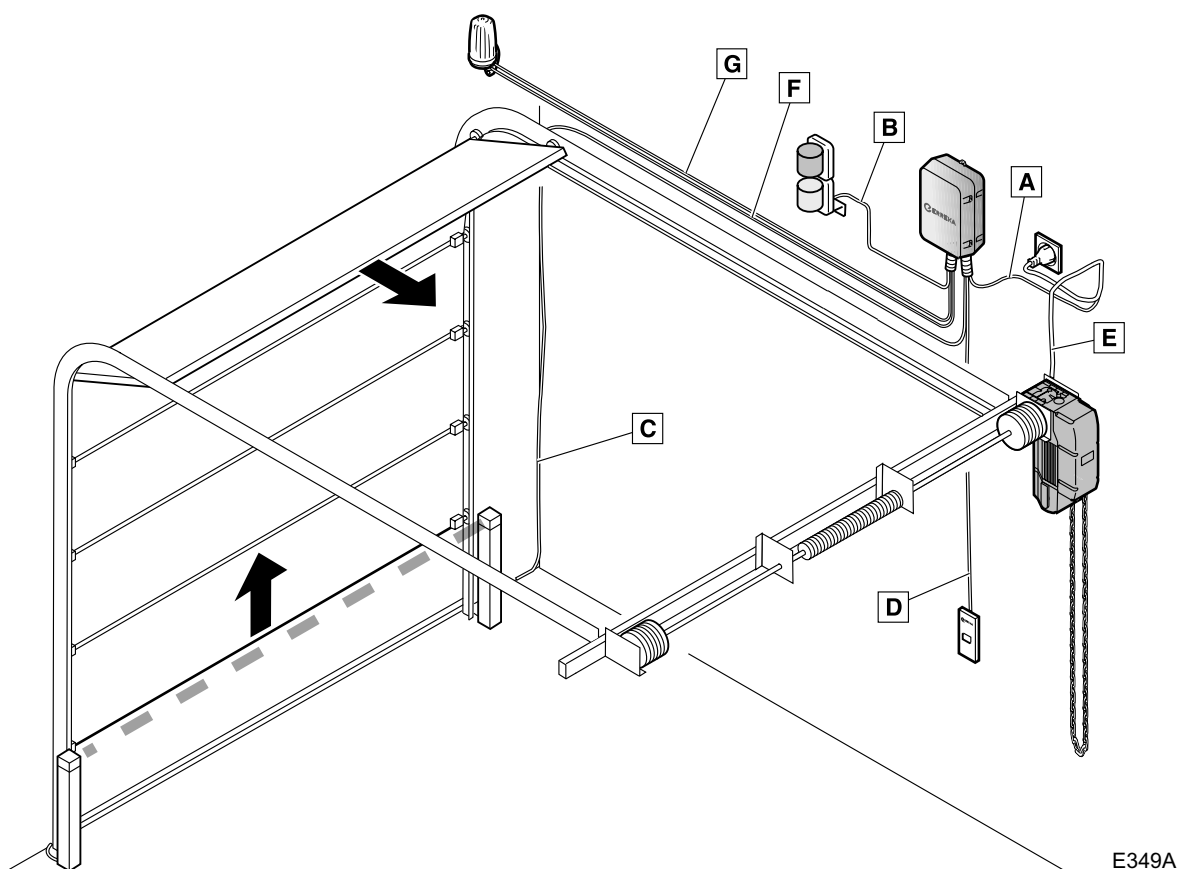

ELECTRICAL CABLING:

Element	N° threads x section	Maximum length
A: Main power supply	ST910C: 3x1.5mm ² ; ST1530C / ST2030C: 3x1.5mm ² , 4x1.5mm ² or 5x1.5mm ² depending on the control panel and connections	30m
B: Traffic light	3x0.5mm ²	20m
C: Photocells (Tx/ Rx)	2x0.5mm ² / 4x0.5mm ²	30m
D: Pushbutton	2x0.5mm ²	25m
E: Operator / Limit switches	4x1mm ² / 5x0.5mm ²	20m
F/G: Flashing light / antenna	2x0.5mm ² / coaxial cable 50Ω (RG-58/U)	20m / 5m

Dimensions (mm)

ST910C / ST1530C

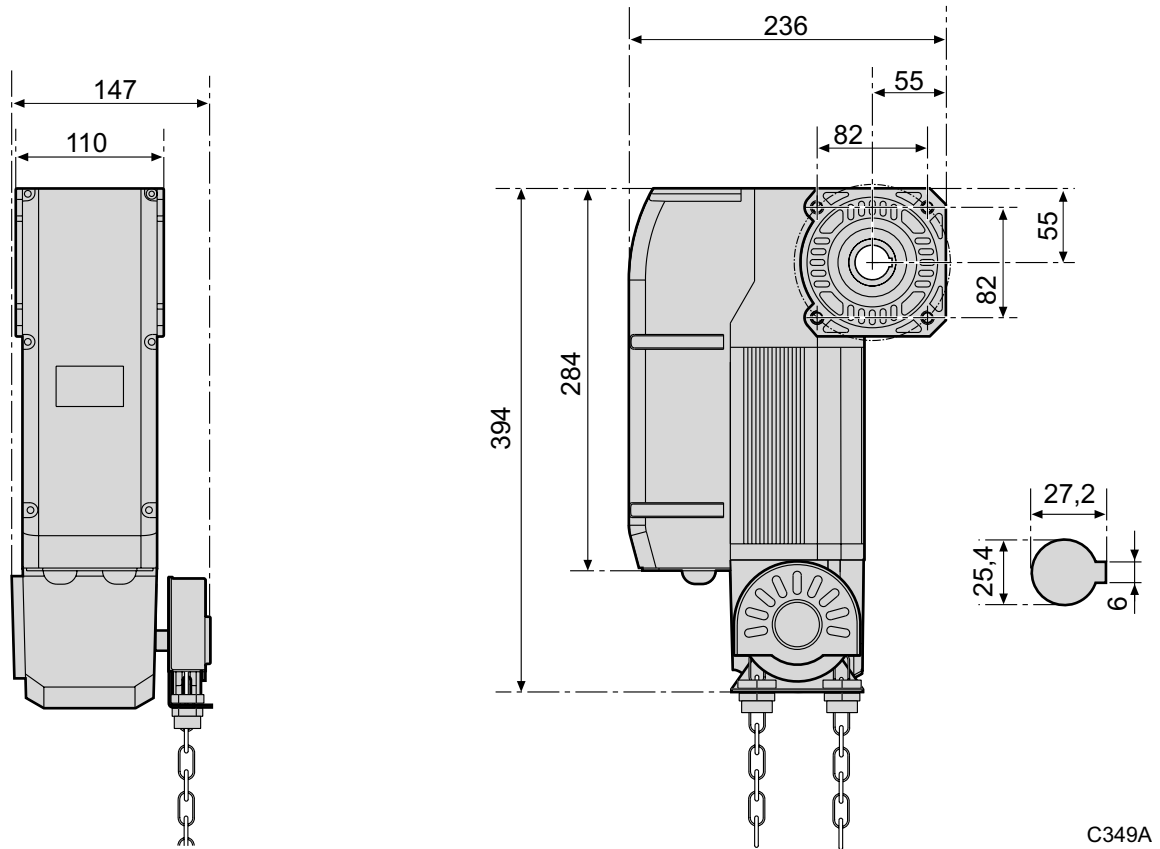

ST2030C

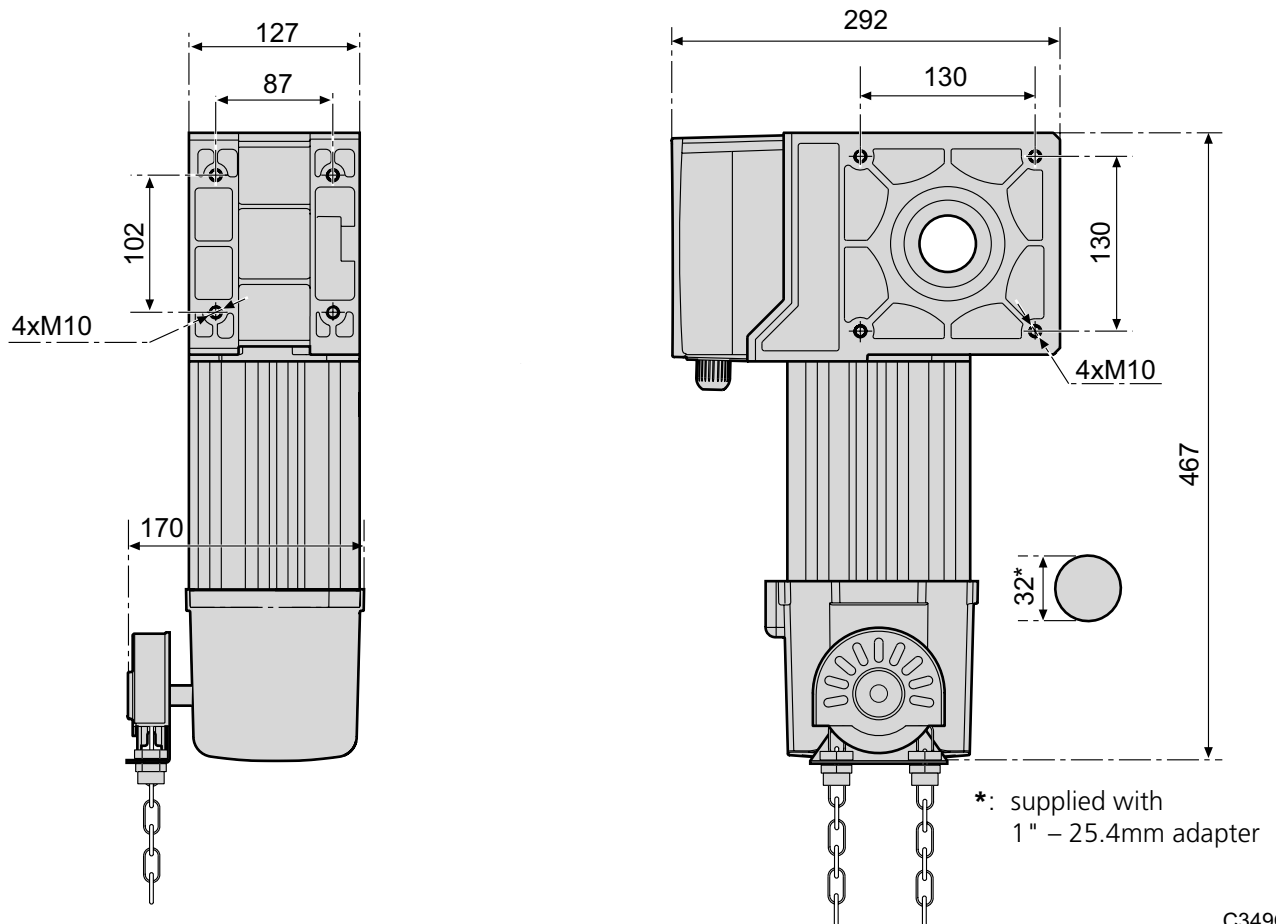

Technical characteristics

	ST910C	ST1530C	ST2030C
Power supply (V/Hz)	230/50	3x400/50 or 3x230/50	
Power (W)	700	650	800
Capacitor (µF)	32	No	
Maximum torque (Nm)	90	150	200
Speed (r.p.m.)	24		16
Output shaft diameter (mm)	25.4		32 (includes adapter 25.4 mm)
Locking	Yes		
Manual operation	Chain drive		
Limit switches	Yes, 20 turns output shaft		
Duty cycle S3 (%)	25%	60%	
Thermal protector (°C)	120		
Noise (dB)	<55		
Protection class (IP)	IP54		
Operating temperature (°C)	-20 / +45		
Operator weight (kg)	16	18	24
Maximum door surface (m ²)	30	50	60

Securing the operator

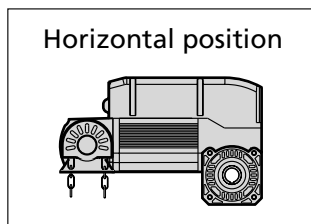
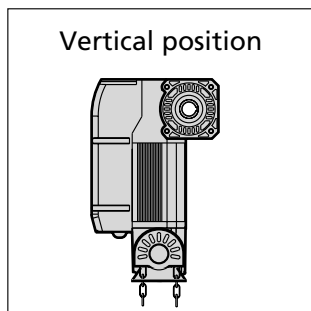

☞ The operator can be fixed in vertical or horizontal position.

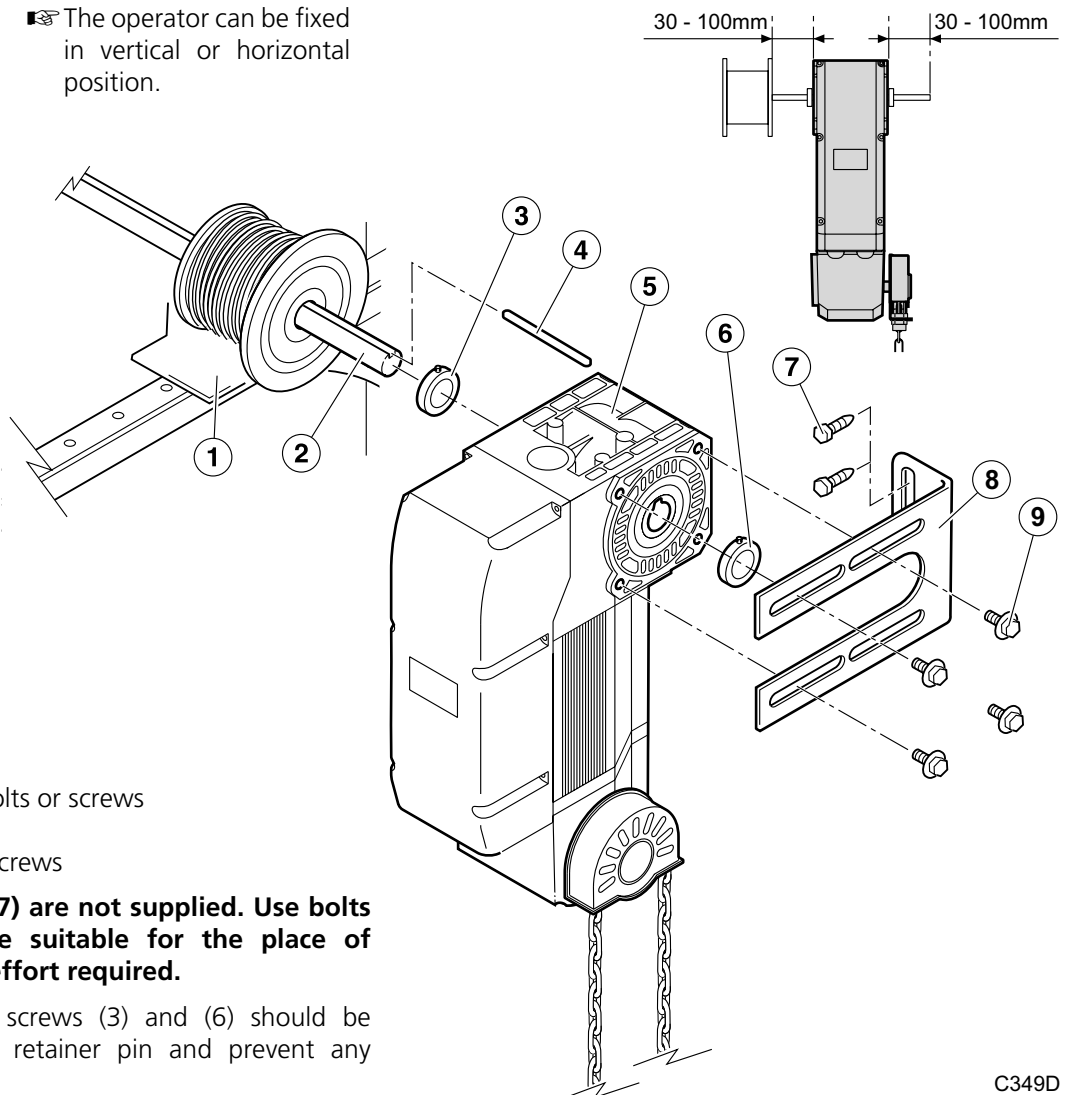

- 1 Door structure
- 2 Keyed door shaft
- 3 Retainer pin ring
- 4 Cotter pin
- 5 Operator
- 6 Retainer pin ring
- 7 Support attachment bolts or screws
- 8 Operator support
- 9 Operator attachment screws

⚠ **The bolts or screws (7) are not supplied. Use bolts or screws which are suitable for the place of attachment and the effort required.**

ⓘ The retainer pin ring screws (3) and (6) should be tightened to lock the retainer pin and prevent any sideways movement.

Manual operation

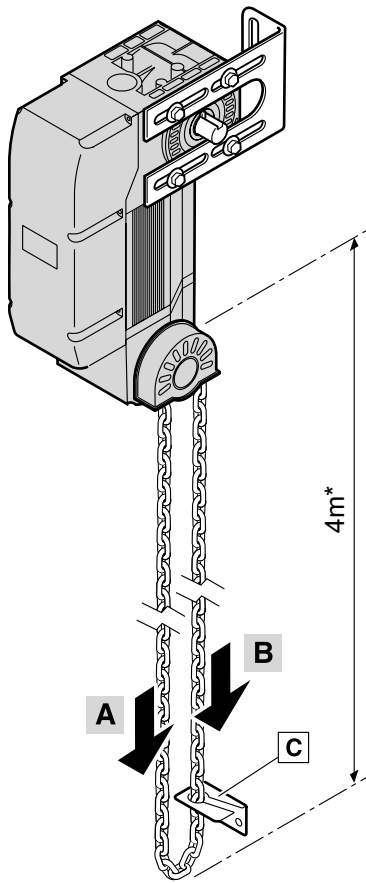

OPENING: to open the door manually, pull on the chain in accordance with arrow A (it is not necessary to unlock the operator or to relock it).

⚠ The chain should move vertically so as not to damage the operator (both in opening and in closing).

CLOSING: to close the door manually, pull on the chain in accordance with arrow B.

*: The length of the extended chain is 8m, so its height is approximately 4m. If you need more chain length, you can order **AST01** accessory, additional meters of chain.

Chain guiding bracket

☞ **Make sure the chain guiding bracket [C] is installed correctly.**

This bracket prevents uncontrolled chain movements when the operator starts up again and moves the chain.

I349D

Limit switches adjustment

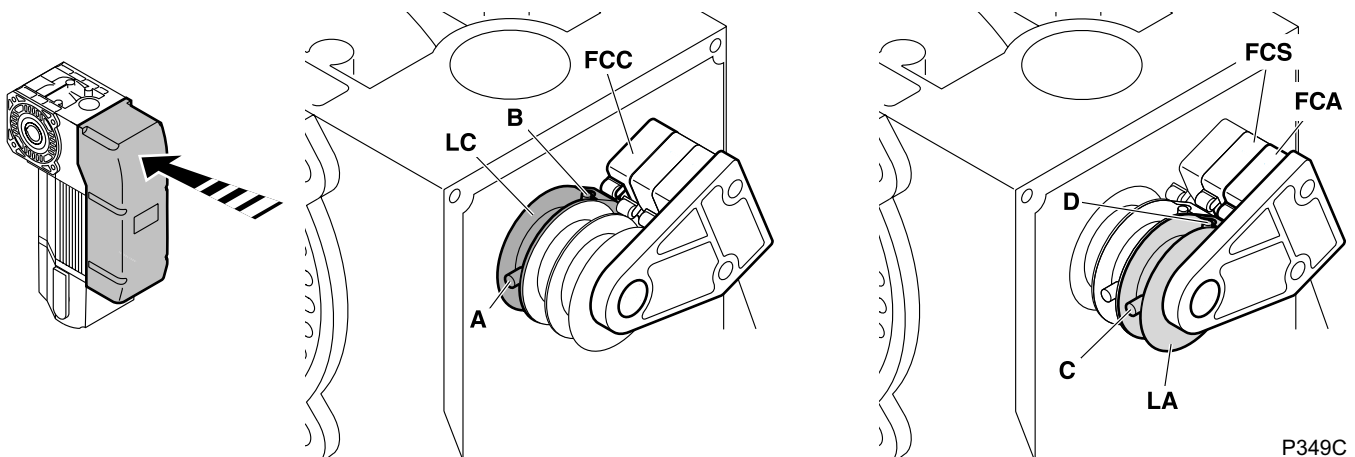

P349C

Closing limit switch (FCC)

- 1 Close the door manually.
- 2 Adjust the LC camshaft (red) for the FCC limit switch to open.
- 3 Tighten screw A to secure the camshaft. Fine adjustment is done by turning screw B.
- 4 Carry out an operation test (having completed the electrical connections as explained in the following section), and then check the torque of screw A.

Opening limit switch (FCA)

- 1 Open the door manually.
- 2 Adjust the LA camshaft (green) for the limit switch to open (FCA).
- 3 Tighten screw C to secure the camshaft. Fine adjustment is done using screw D.
- 4 Carry out an operation test (having completed the electrical connections as explained in the following section), and then check the torque of screw C.

Additional limit switch FCS (contact normally open): will be used in accordance with the requirements of each installation or customer. Adjustment is the same as for FCA and FCC.

ST910C single-phase connections with AM606 control panel

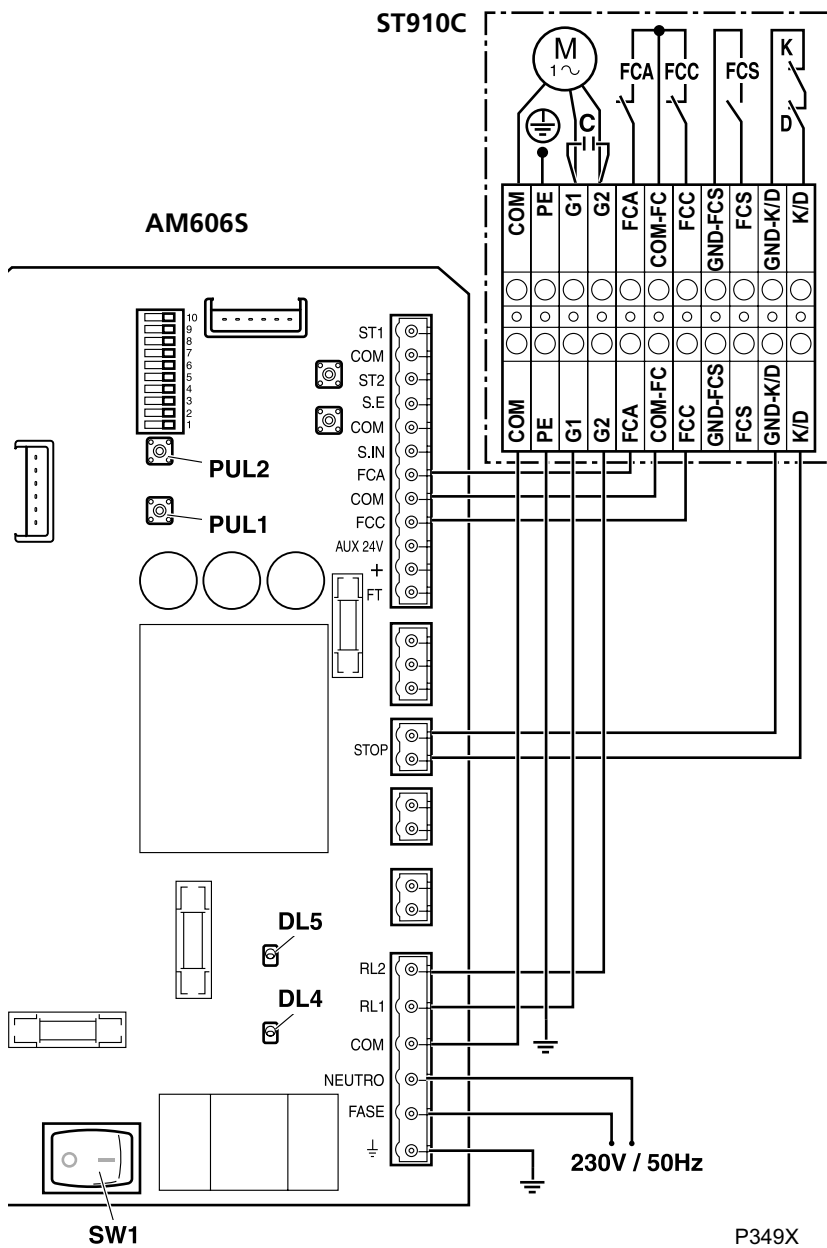

Operator parts ST910C:

- M: Single-phase motor
- C: Capacitor
- FCA: Opening limit switch
- FCC: Closing limit switch
- FCS: Additional limit switch (to be used in accordance with the requirements of the customer or installation)
- K: Thermal protector
- D: Unlock switch

Control board parts (AM606S):

- DL4: Open LED
- DL5: Close LED
- PUL1: Close mini-pushbutton
- PUL2: Open mini-pushbutton
- SW1: Main switch

Operator connections ST910C:

- COM Common motor
 - PE Earth connection
 - G1 Turn 1 motor
 - G2 Turn 2 motor
 - FCA Opening limit switch
 - COM-FC FCA and FCC limit switches common
 - FCC Closing limit switch
 - GND-FCS FCS common
 - FCS Additional limit switch
 - GND-K/D K/D common
 - K/D Thermal protector / unlock switch
- ☞ When pressing PUL1 (close), DL5 lights up and the COM and RL2 cable connectors are activated.
 - ☞ When pressing PUL2 (open), DL4 lights up and the COM and RL1 cable connectors are activated.
 - ☞ If the operator turns in the opposite direction to that required, interchange connections RL1 and RL2.

Connection to switchboard without STOP cable connectors

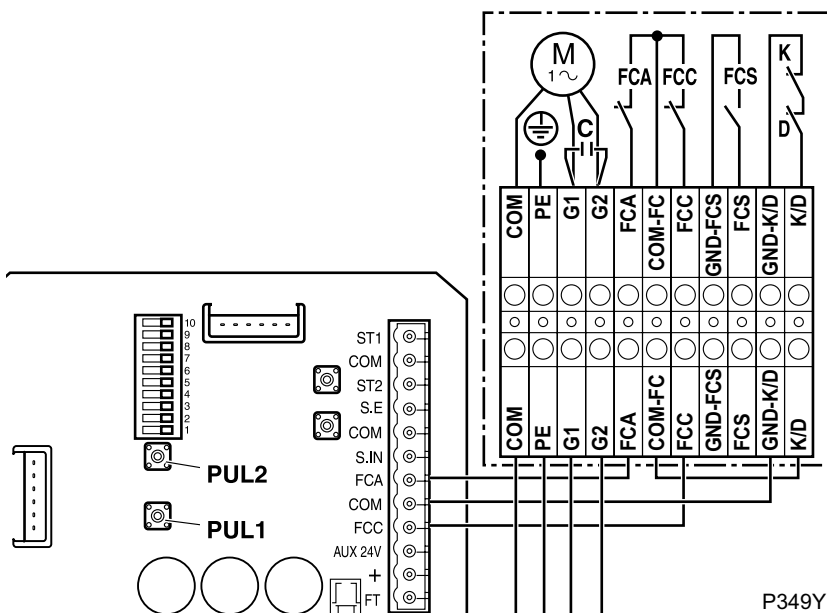

Although not recommended, it is possible to use a switchboard which does not have STOP cable connectors. In this case, make the connections as shown in the diagram (D and K connect in series to the COM-FC cable connector of the limit switches).

- ⚠ If K or D is activated (operator overheated or unlocked), do not run PUL1 or PUL2 (open and close mini-pushbuttons) as this may cause damage to the operator.

ST910C single-phase connections with VIVO-M101PT control panel

The VIVO-M101PT control panel allows use of single-phase operators with power above that allowed with the VIVO-M101 panel.

The VIVO-M101PT control panel is a variant of the VIVO-T101 control panel that can be used with single-phase motors, connecting it as shown in the figure.

⚠ There is no "soft stop" function.

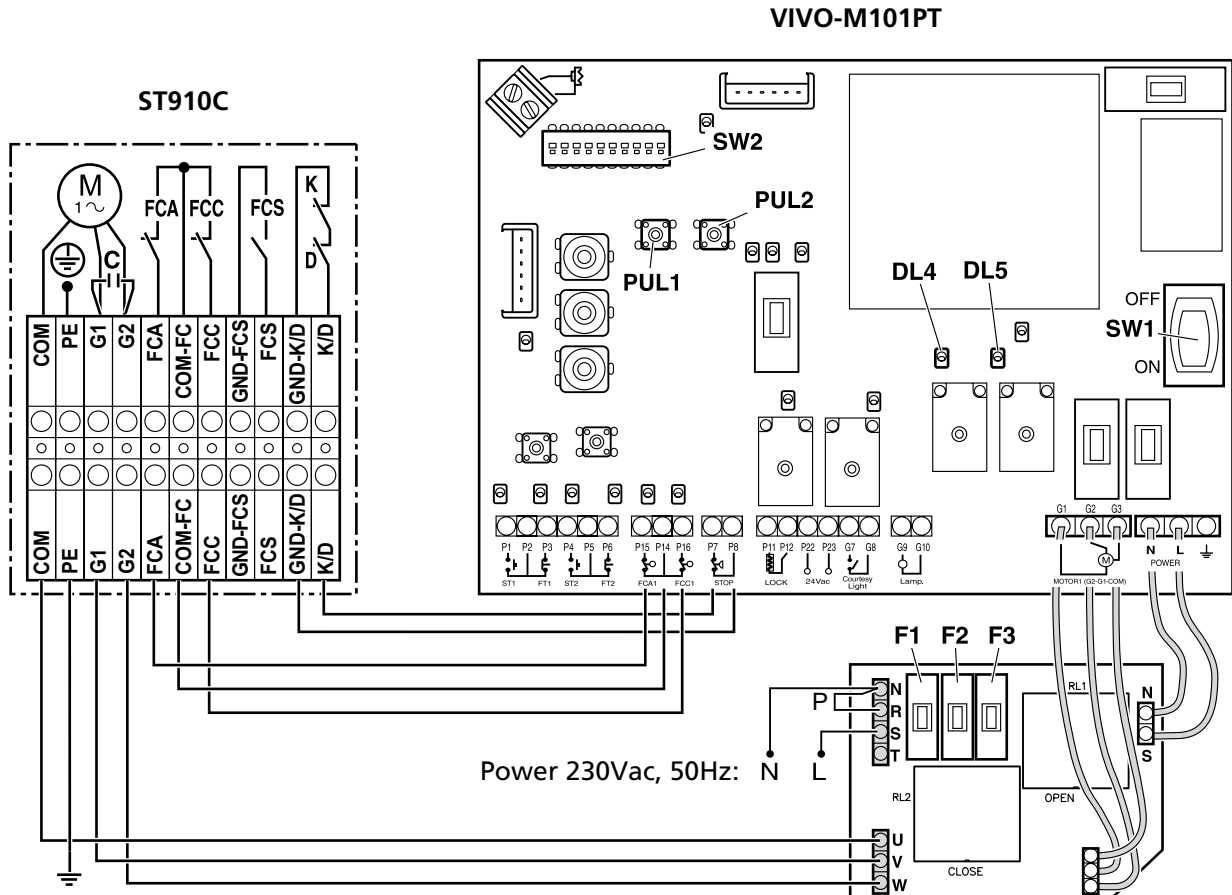

P349V

Operator parts ST910C:

- M: Single-phase motor
- C: Capacitor
- FCA: Opening limit switch
- FCC: Closing limit switch
- FCS: Additional limit switch (to be used in accordance with the requirements of the customer or installation)
- K: Thermal protector
- D: Unlock switch

Control board parts (VIVO-M101PT):

- DL4: open indicator
- DL5: close indicator
- PUL1: close mini-pushbutton
- PUL2: open mini-pushbutton
- SW1: power switch
- SW2: programming DIPs
- F1: R line fuse (6,3A)
- F2: S line fuse (6,3A)
- F3: T line fuse (6,3A)

Operator connections ST910C:

- COM: Common motor
- PE: Earth connection
- G1: Turn 1 motor
- G2: Turn 2 motor
- FCA: Opening limit switch
- COM-FC: FCA and FCC limit switches common
- FCC: Closing limit switch
- GND-FCS: FCS common
- FCS: Additional limit switch
- GND-K/D: K/D common
- K/D: Thermal protector / unlock switch

- ☛ When PUL1 (close) is pressed, DL5 lights up and the CLOSE relay (RL2) is activated.
- ☛ When PUL2 (open) is pressed, DL4 lights up and the OPEN relay (RL1) is activated.
- ☛ If the operator turns in the opposite direction to that required, interchange connections V and W.

Three-phase ST1530C and ST2030C connections with VIVO-T101 control panel

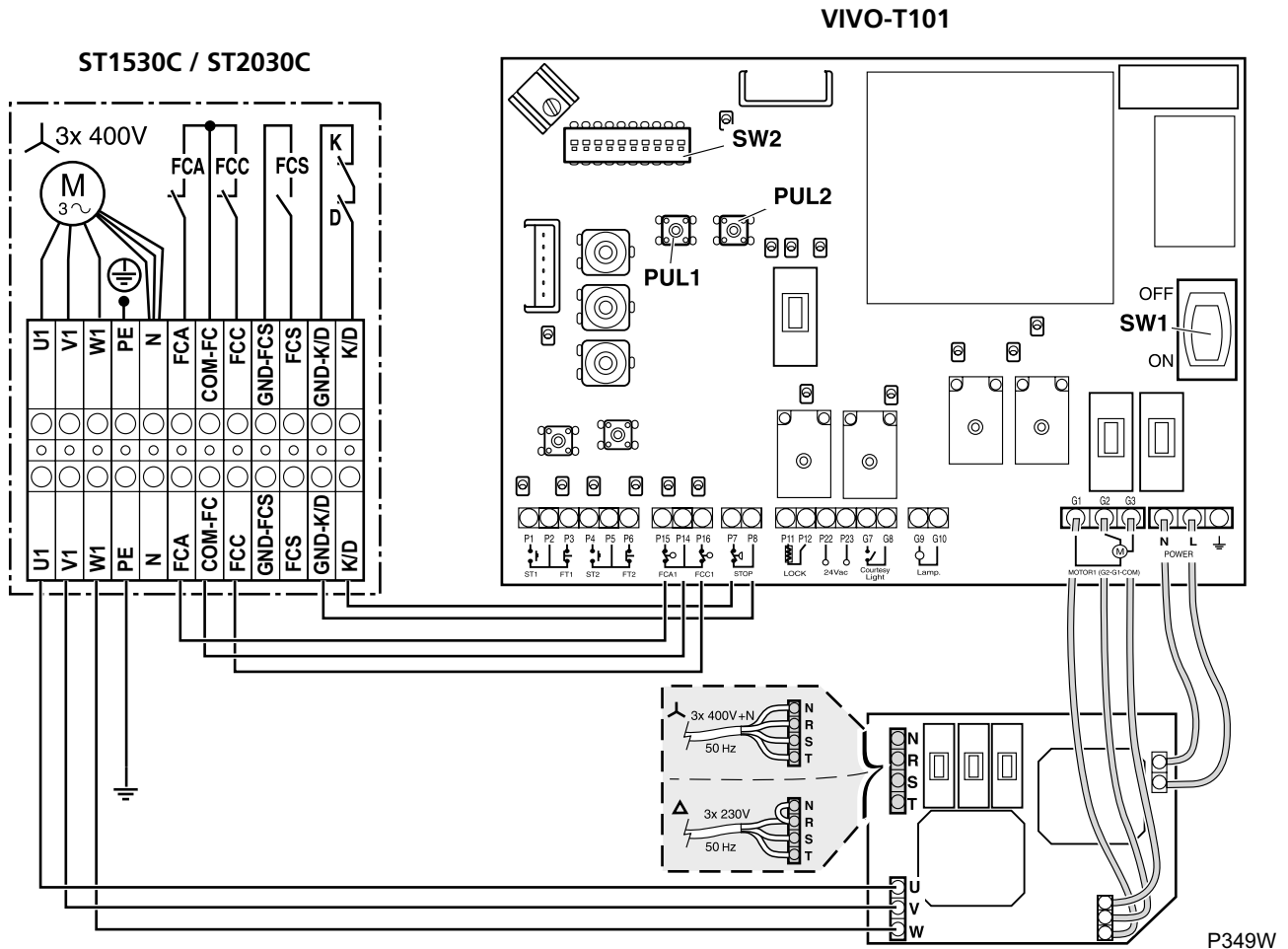

Operator parts (ST1530C, ST2030C):

- M: Three-phase motor
- FCA: Opening limit switch
- FCC: Closing limit switch
- FCS: Additional limit switch (to be used in accordance with the requirements of the customer or installation)
- K: Thermal protector
- D: Unlock switch

Control board parts (VIVO-T101):

- PUL1: close mini-pushbutton
- PUL2: open mini-pushbutton
- SW1: Main switch
- SW2: DIP switch programming

Operator connections (ST1530C, ST2030C):

- U1 U-phase motor
- V1 V-phase motor
- W1 W-phase motor
- PE Earth connection
- N Neutral motor
- FCA Opening limit switch
- COM-FC FCA and FCC limit switches common
- FCC Closing limit switch
- GND-FCS FCS common
- FCS Additional limit switch
- GND-K/D K/D common
- K/D Thermal protector / unlock switch

- ☞ Press PUL1 (close) and PUL2 (open) to check that the turning direction of the operator is correct. If it is not, interchange connections V and W.

- ☞ **The operator in the wiring diagram is for a 3x400V star connection. For 3x230V delta connection, follow the operator modification instruction on the next page.**

Three-phase ST1530C and ST2030C connections with VIVO-I103 control panel

3x 400V

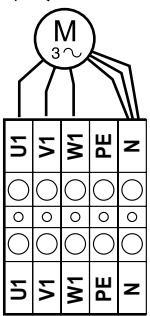

△ 3x 230V

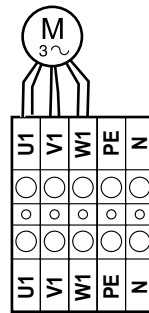

U1: blue
V1: black
W1: white
N: brown + green + gray

Change the ST1530C and ST2030C settings, switching from 3x400V to 3x230V, connecting the cables as follows:

U1: blue + brown
V1: black + green
W1: white + grey
N: wireless

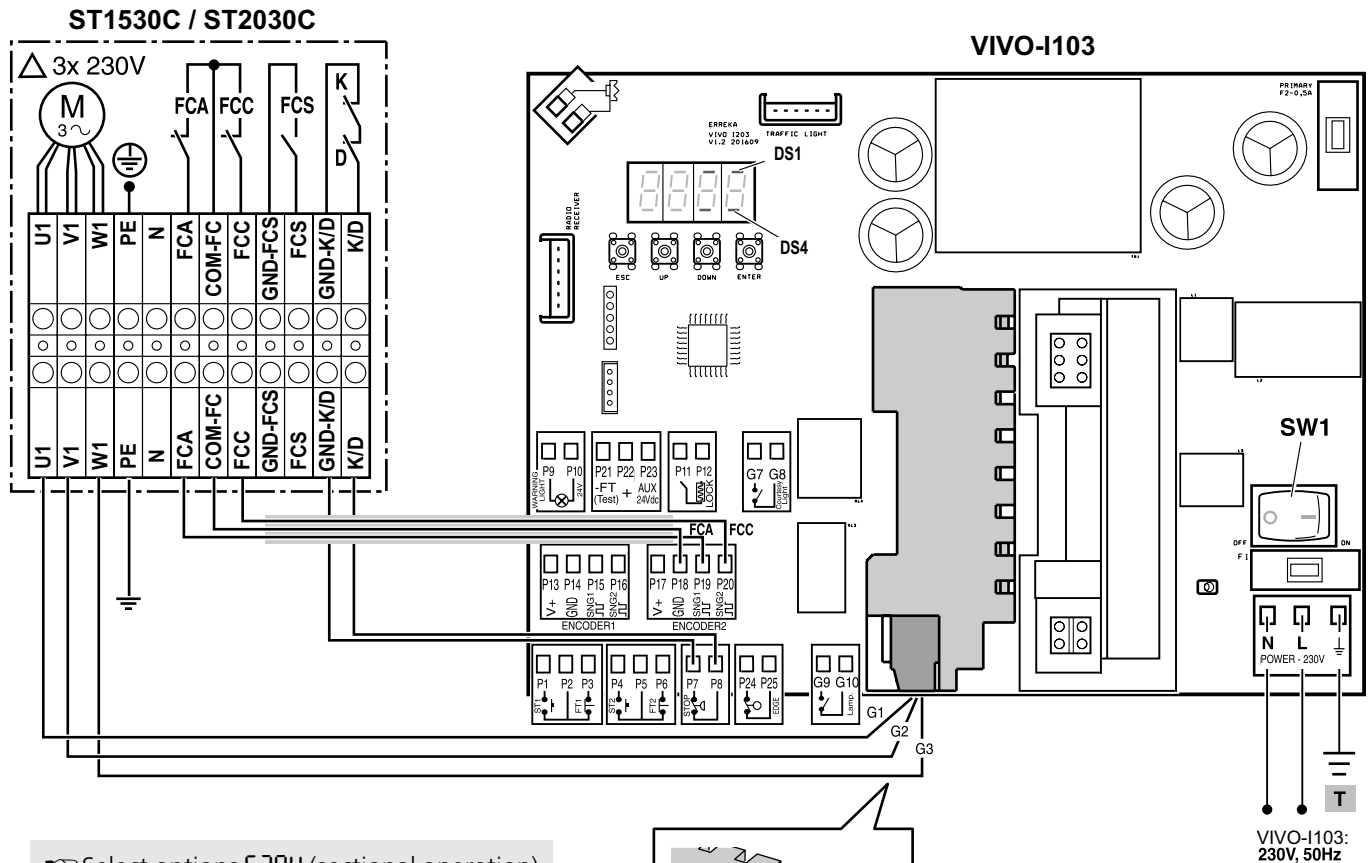

VIVO-I103:
230V, 50Hz

P349U

☞ Select options **304** (sectional operation) and **702** (limit switches).

☞ Check turning direction using UP and DOWN in parameter **101**. If it is not correct, select **102** (see the control board instructions for further information).

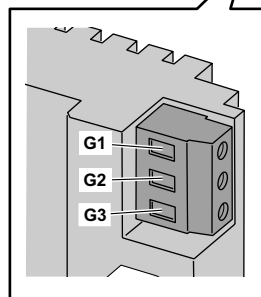

Operator parts (ST1530C, ST2030C):

M: Three-phase motor
FCA: Opening limit switch
FCC: Closing limit switch
FCS: Additional limit switch (to be used in accordance with the requirements of the customer or installation)
K: Thermal protector
D: Unlock switch

Control board parts (VIVO-I103):

DS1: LED SNG1 (FCA)
DS4: LED SNG2 (FCC)
SW1: Main switch

Operator connections (ST1530C, ST2030C):

U1 U-phase motor
V1 V-phase motor
W1 W-phase motor
PE Earth connection
FCA Opening limit switch
COM-FC FCA and FCC limit switches common
FCC Closing limit switch
GND-FCS FCS common
FCS Additional limit switch
GND-K/D K/D common
K/D Thermal protector / unlock switch