

CHAIN BARRIER

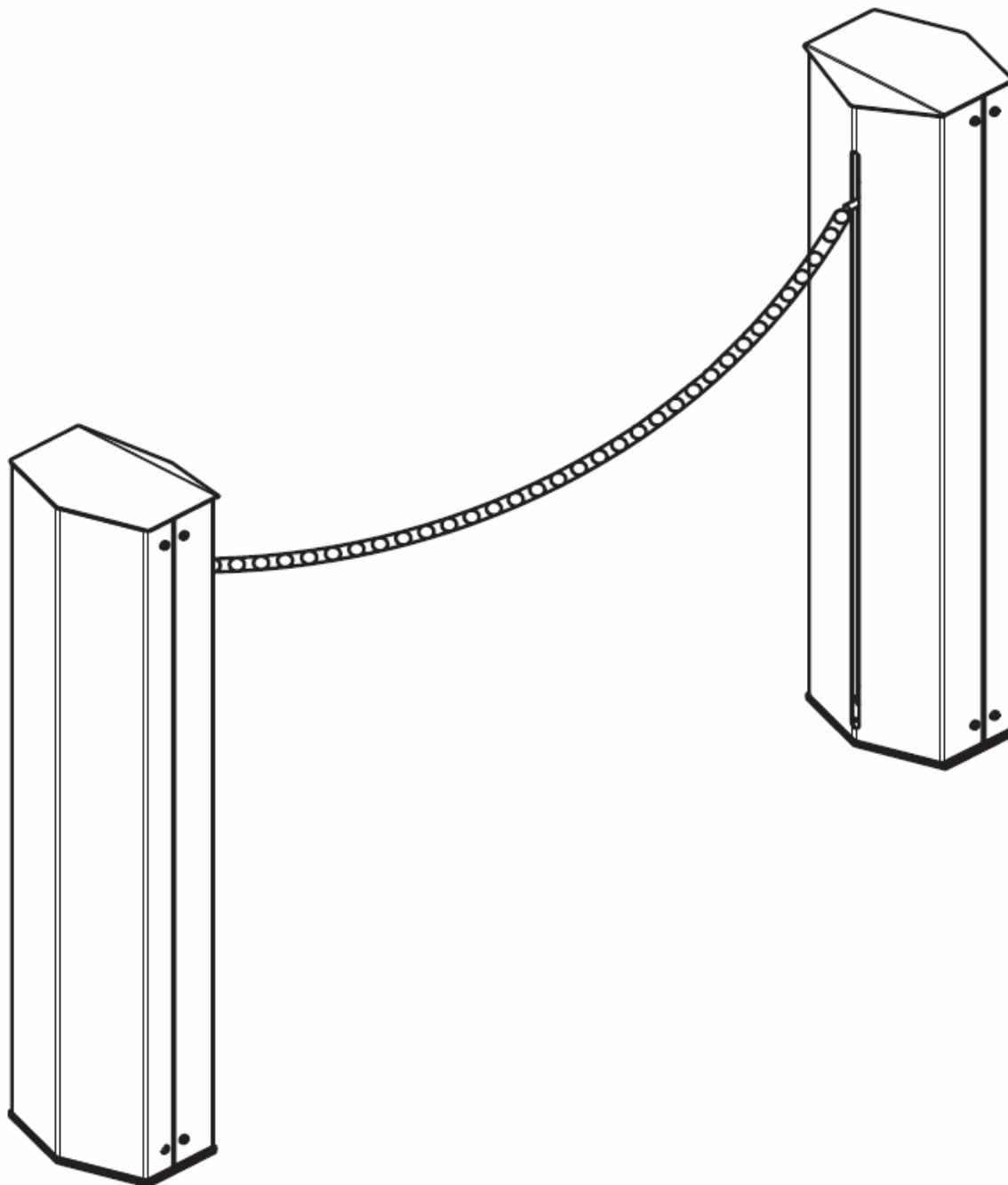

1. Lay-out

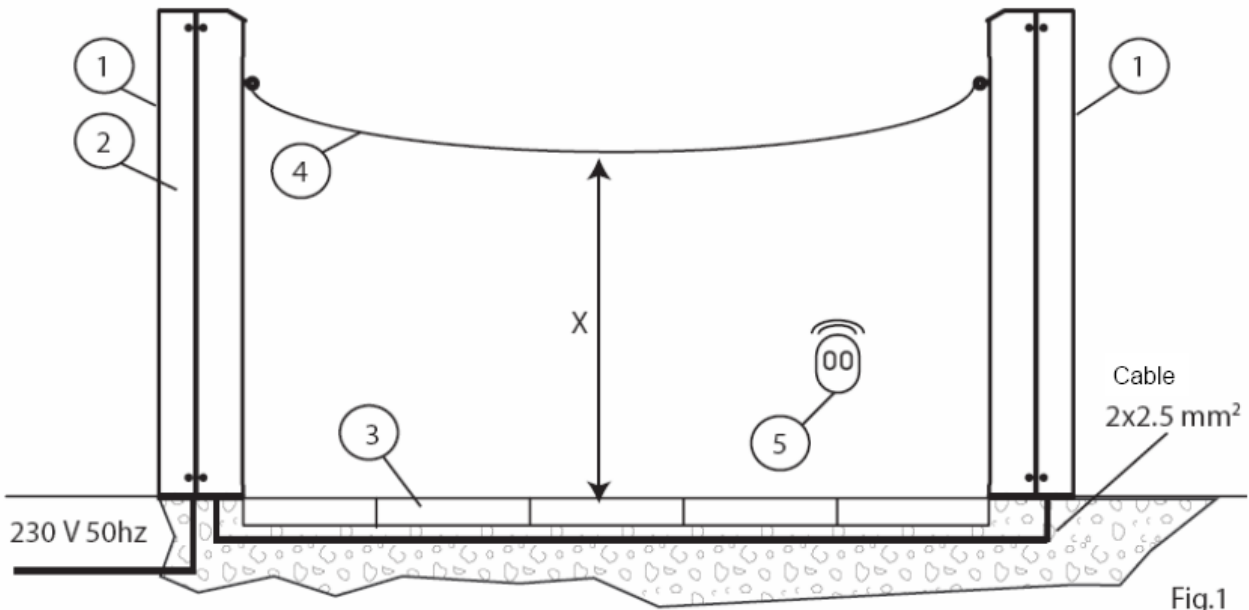

Fig.1

Length of the chain (m)	4	6	8	10	12	14	16	18	20
Relative height in the middle X (cm)	75	70	65	60	55	50	45	40	35

Description:

- [1] Chain barrier Tecno Cat New
- [2] Control unit
- [3] Profile for the chain below ground
- [4] Chain
- [5] Radio transmitter

Attention: The value in the table has been determined using a chain of 400 grams/meter

2. Description and dimension of the column

Description:

- [1] Column
- [2] Gear motor with encoder
- [3] Control unit
- [4] Auto blocking nut M10
- [5] Washer 20x10
- [6] Backing plat
- [7] Screw M10x70
- [8] Anterior cover
- [9] Posterior cover
- [10] Closing screw M5x10

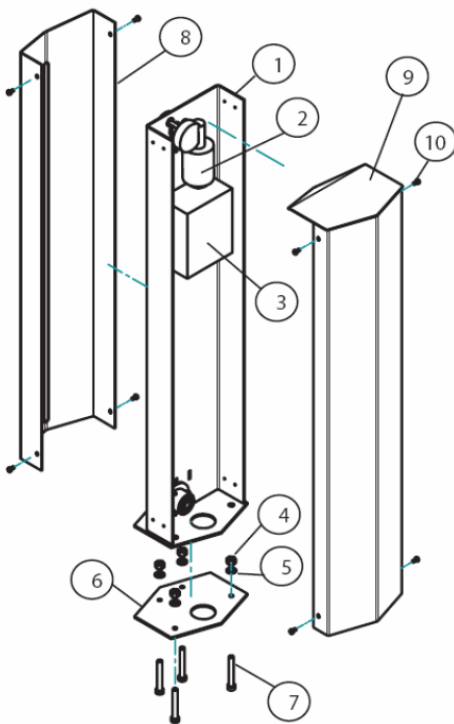

Fig.4

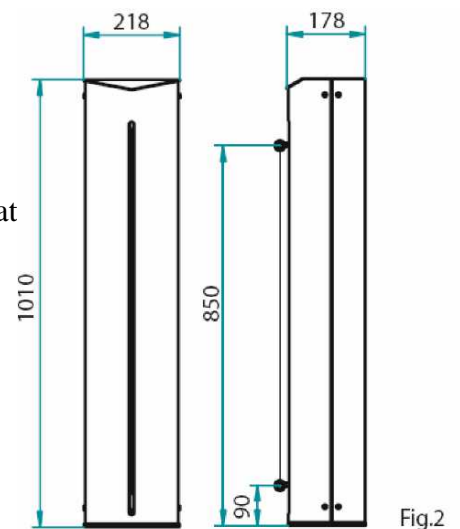

Fig.2

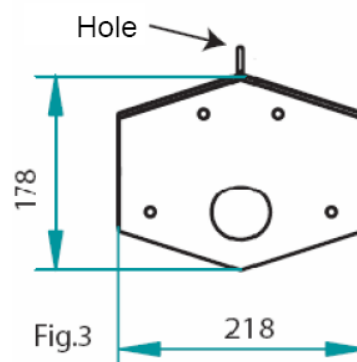
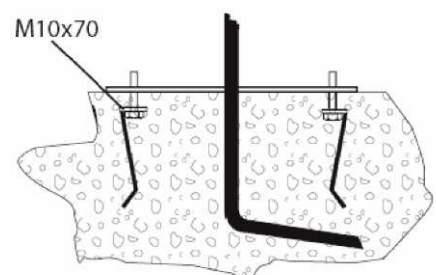

Fig.3



3. Installation

All measures are expressed in millimeters unless otherwise indicated.

3.1. Preliminary controls

1. Control the stability and solidity of the zone where the columns are going to be fixed.
2. Use an omnipolar interrupter with contact distance of at least 3mm.
3. The connection to the power supply must be separated than the connections to the security and commanding devices.

3.2. Installation of the column (Fig. 1, Fig. 3, Fig. 4)

1. Screw in for 1,5 - 2,0 cm the 4 screws M10x70 in dotation to the base.
2. Place than the base on the previously prepared base of cement (Fig.3)
3. The upper part of the base should be clean and perfectly horizontal.
4. Pass the plastic tubes of the cables through the central opening on the base and check again the stability of the base.
5. Unscrewing the 8 screws [10] take off the frontal [8] and the rear cover [9] of the column (Fig. 4)
6. Place now the column structure on the base.
7. Fix now the column to the base with the 4 washers [5] and 4 nuts [4].
8. Fix the frontal covers [8] of both columns with 4 screws [10].
9. Now you can fix the chain to the apposite holes on both columns respecting the level X in the middle of the chain barrier indicated at the table on page 1 (Fig. 5)

3.3. Electrical connections

Please refer to the instructions of the control unit ACTION for the chain barrier (code: 61622349).

4. Maintenance plan (every 6 months)

1. Cut the power supply off or disconnect the batteries if present. Clean and grease the guide and the pignons internally.
2. See if there are wired parts and replace these if necessary
3. Grease the internal transmitting chain.
4. Check the fixation nuts
5. Control the electrical connections
6. Supply the power again
7. Check out the correct functioning of the obstacle recognition (encoder system)
8. Check out the correct functioning of all and of the security commands

5. CONNECTION OF THE BRAKING JOINT



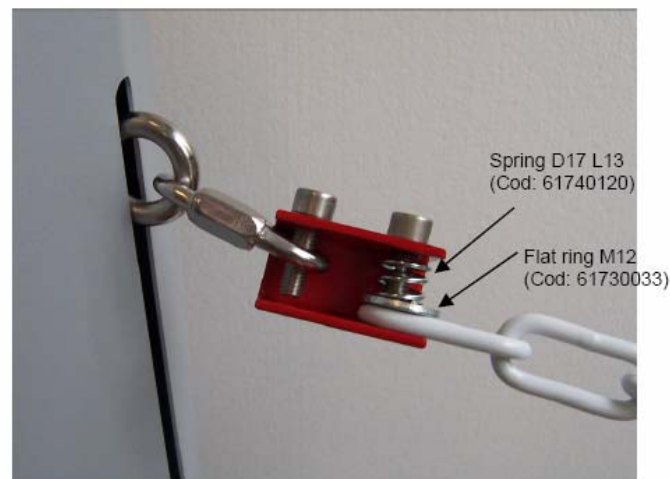
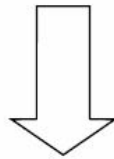

6. Technical Data

Power supply:	230 Vac 50 Hz
Current Draw:	1.0 A
Motor Power:	60 W
Force:	645 Nm
Service:	50 %
Protection Degree:	IP 34
Lubrication:	Permanent
Weight:	25 Kg
Max chain weight:	8.5Kg

GUARANTEE - In compliance with legislation, the manufacturer's guarantee is valid from the date stamped on the product and is restricted to the repair or free replacement of the parts accepted by the manufacturer as being defective due to poor quality materials or manufacturing defects. The guarantee does not cover damage or defects caused by external agents, faulty maintenance, overloading, natural wear and tear, choice of incorrect product, assembly errors, or any other cause not imputable to the manufacturer. Products that have been misused will not be guaranteed or repaired. Printed specifications are only indicative. The manufacturer does not accept any responsibility for range reductions or malfunctions caused by environmental interference. The manufacturer's responsibility for damage caused to persons resulting from accidents of any nature caused by our defective products, are only those responsibilities that come under Italian law.

General connections

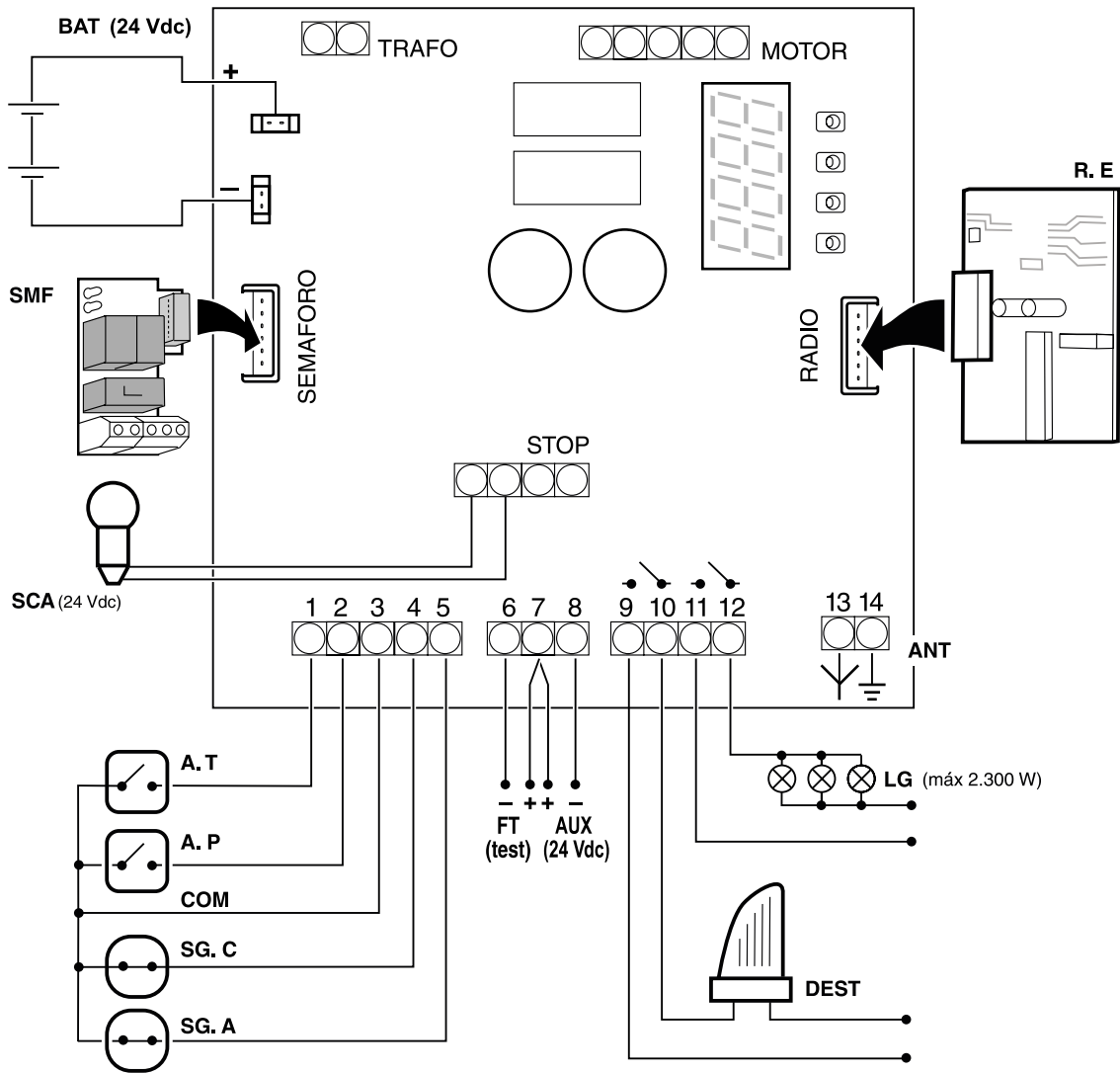

Display indications

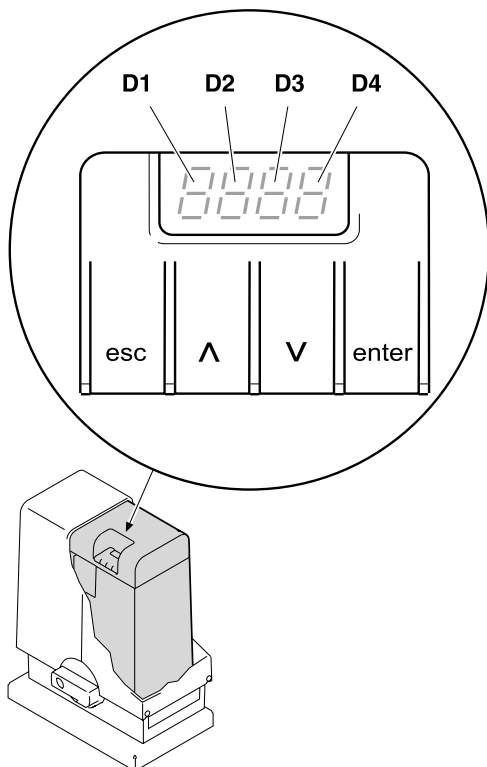

D1 and D2:

[L (static)	Gate closed
[L (flashing)	Gate closed
OP (static)	Gate open
OP (flashing)	Gate opening
XX (countdown)	Gate on standby
STOP	Actuator unlocked
PR (static)	Pause (operation not complete)
rS (static)	Gate searching for close position

D3 and D4:

[4	Opening safety device activated
[5	Closing safety device activated
E i	Encoder motor halted
F i	Force limit exceeded
bR	Battery working
Ftno	Photocells defective (testing)

Radio code recording (only with RSD-001 receiver)

☞ If a receiver other than RSD-001 is used, see the corresponding instructions.

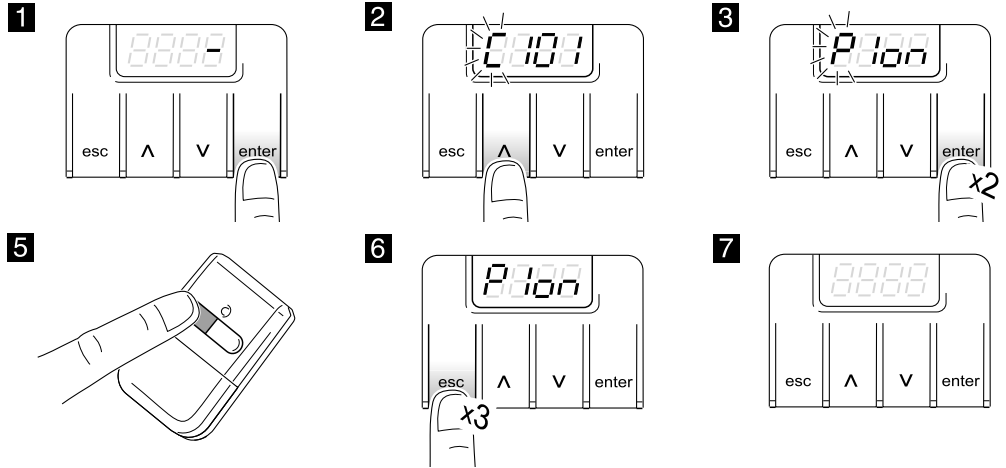

Travel recording

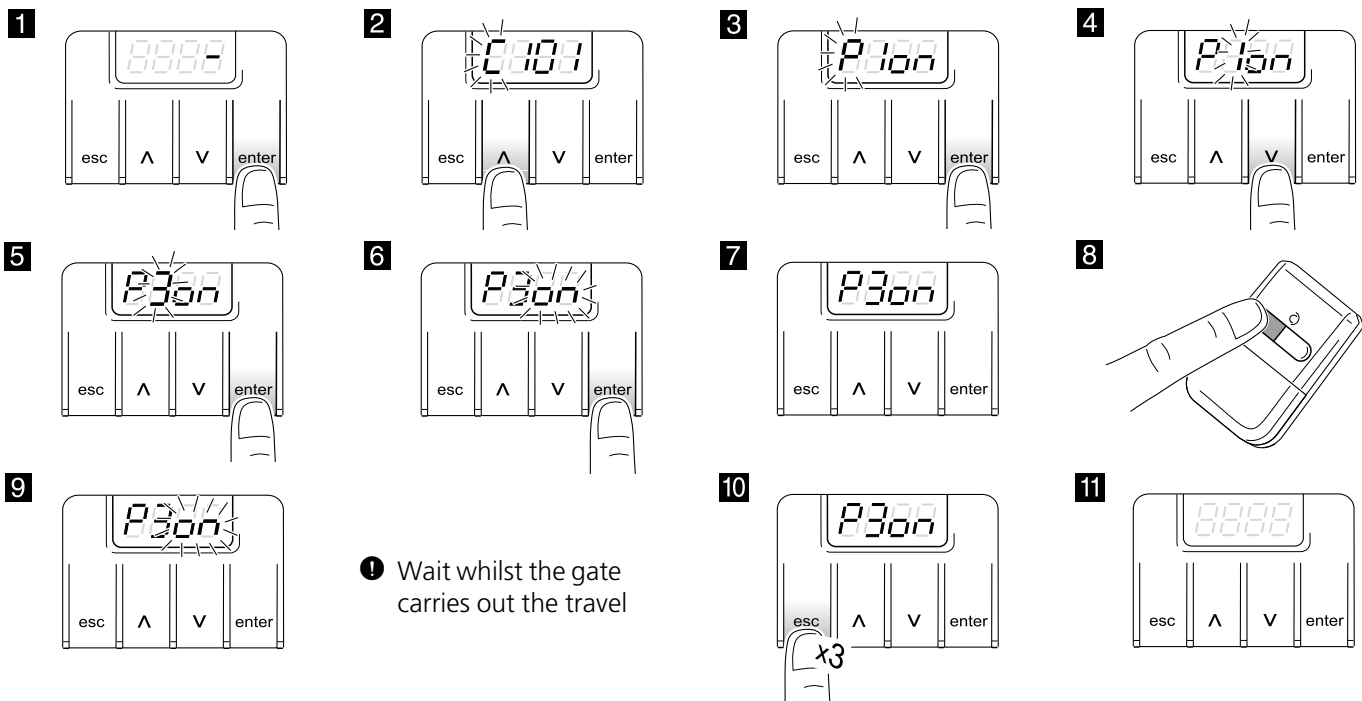

Complete programming chart

D1	D2	Parameter	D3	D4	Pre-determined option	Options or values
C	1	Motor rotation direction	0	2	x	
	4	Opening safety device (photocell or strip)	0	0	x	Device not installed
	5	Closing safety device (photocell or strip)	0	0	x	Device not installed
			1	0		Device without testing
			1	1		Device with testing
P	1	Total opening radio code recording	0	n		
	2	Pedestrian opening radio code recording	0	n		
	3	Gate travel recording	0	n		
F	1	Operation mode	0	1		Automatic
			0	2	x	Semi-automatic
	2	Standby in automatic mode	0...5	0...9	15	59 = 59 sec; 2.5 = 2 min. 50 sec, etc
	3	Pedestrian opening	0	0	x	Pedestrian opening is not carried out
R	0	Flashing light	0	1	x	No warning
			0	2		With warning
	1	Garage light time	0...5	0...9	03	59 = 59 sec; 2.5 = 2 min. 50 sec, etc
	2	Gate speed	0	1...5	03	0 1: minimum speed; 05: maximum speed
	3	Soft stop speed	0	1...5	02	0 1: minimum speed; 05: maximum speed
	4	Soft stop function	0	0...5	0 1	00: minimum distance; 05: maximum distance
	6	Maximum force	0... 1	0...9	05	0 1: minimum force; 10: maximum force
	7	Closing photocell used during standby (in automatic mode only)	0	1		Immediate close
			0	2	x	Restart standby time
			0	3		Has no effect
	8	Pushbutton operation during standby (in automatic mode only)	0	1		Immediate close
			0	2	x	Restart standby time
			0	3		Has no effect
	9	Opening mode	0	1		Opening in accordance with the mode selected in the main functions (F)
			0	2	x	Community opening (the control panel does not obey the commands during opening)
0			3		Step-by-step opening (the gate halts if an operation device is activated during opening. The gate closes when operated again)	
n	1	Operations carried out	X	X		Indicates the hundreds of cycles completed (for example, 68 indicates 6,800 cycles completed)