

USER MANUAL

**AUTOMATIC PEDESTRIAN DOOR
ERTAIN 4 – GLOBAL 4 – TELESCOPIC 4**



CONTENTS

1. INTRODUCTION	3
2. TECHNICAL CHARACTERISTICS	3
3. GENERAL DESCRIPTION	3
4. OPERATION	4
5. SAFETY ELEMENTS	6
6. EXTERIOR KEY (Opening pulse/Closing pulse)	6
7. DOORS WITH ANTI-PANIC FITTING (Optional)	7
8. DOORS WITH ELASTIC KIT - C048 (Optional)	7
9. USER PARAMETERS CONFIGURATION	7
10. LOCATION OF FAILURES AND ACTION PROCEDURE	9
11. PROCEDURE IN THE EVENT OF POWER FAILURE	9
12. TECHNICAL SUPPORT	10
13. MAINTENANCE	10
14. WARRANTY	10
15. MAINTENANCE BOOK	11

1. INTRODUCTION

This manual has been drafted in accordance with international standards UNE-EN-ISO 12100 and UNE EN 16005.

ERREKA operators are designed for intensive use, guaranteeing a maximum level of safety and a long working life. The information in this manual is for the ERTAIN 4, GLOBAL 4 AND TELESCOPIC 4 System models, and describes the instructions necessary for proper handling and operation of the automatic door.

2. TECHNICAL CHARACTERISTICS

CHARACTERISTICS	ERTAIN 4	GLOBAL 4	TELESCOPIC 4
Maximum weight per leaf (2 leaves)	100 + 100 kg	140 + 140 kg	70 + 70 + 70 + 70 kg
Maximum weight per leaf (1 leaf)	140 kg	200 kg	100 + 100 kg
Opening speed	0,2 – 0,8 m/s	0,2 – 0,8 m/s	0,2 – 0,8 m/s
Closing speed	0,1 – 0,5 m/s	0,1 – 0,5 m/s	0,1 – 0,5 m/s
Maximum closing force	150 N	150 N	150 N
Atmospheric temperature	-20 °C / +50 °C	-20 °C / +50 °C	-20 °C / +50 °C
Power supply *	230 V ~ (± 10 %) 50 Hz	230 V ~ (± 10 %) 50 Hz	230 V ~ (± 10 %) 50 Hz
Consumption	100 W	200 W	200 W
Batteries	NiCd (24 V)	NiCd (24 V)	NiCd (24 V)



*Depending on the grid, this may be fed at: 110 V ~ (± 10 %) / 60 Hz

3. GENERAL DESCRIPTION

1. Operator.
- 2a. Internal movement sensor.
- 2b. External movement sensor.
3. Safety sensor.
4. Interior release handle
5. Moveable leaf.
6. Fixed leaf.
7. Infra-red barrier.
8. Digital selector.
9. Rotary key selector.
10. Exterior key.
11. Floor guide.

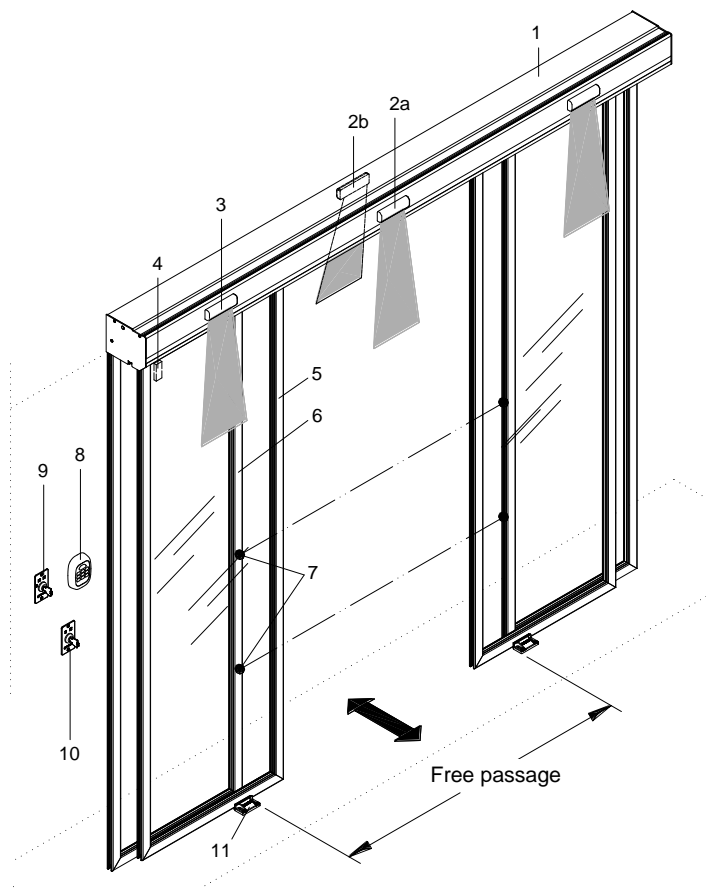

4. OPERATION

4.1 Digital Selector

	Symbol	Function	Description
		Door Open	The door opens and remains open in maximum opening position.
		Automatic	When a signal is received from the radar contact, the door opens, remains open for the programmed time, and closes again.
		Door closed	The door closes and the electro-lock, if fitted, is activated to prevent it opening.
		Exit only	The door only allows exit from the site. When the door closes, it also locks to prevent manual opening from outside.
		Winter mode/Partial opening	When pressed, the door opens but with a smaller opening than in total opening. In winter/partial, it works in the following modes: automatic, exit only and door open.
		Manual	The door stops and the motor is released in order to move the leaf manually.

- To **reset**, keep the 2 keys pressed down at the same time for 3 seconds:



- To **lock** the selector (to ensure it cannot be tampered with and the modes and parameters cannot be changed): press the following keys for 3 seconds.



Repeat the sequence to unlock.

When the selector is locked, the icon is displayed on screen. Whilst this icon is displayed, the selector keys are not available until it is unlocked and the icon disappears.

4.2 Rotary Selector

The key rotary selector cannot be used to regulate the door. The digital selector must be connected in order to modify the parameters of the door.

	Symbol	Function	Description
		Door open	The door opens and remains open in maximum opening position.
		Door closed	The door closes and the electro-lock, if fitted, is activated to prevent it opening.
		Automatic	When a signal is received from the radar contact, the door opens, remains open for the programmed time, and closes again.
		Manual	The door stops and the motor is released in order to move the leaf manually.
		Winter mode/Partial opening	The door works as in automatic mode, but with reduced opening (by default, 70% of total opening).
		Exit only	The door only allows exit from the site. When the door closes, it also locks to prevent manual opening from outside.

- To **reset**, press the concealed pushbutton to the right of the exit only icon using a tipped instrument

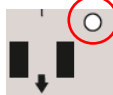

- In the case of error, the indicator LED located to the left of the "exit only" icon will begin to flash.

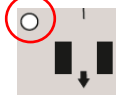

5. SAFETY ELEMENTS

5.1 Safety by electronic control.

ERREKA operators are fitted with an anti-crush system which monitors the force and movement of the leaves at all times to prevent any trapping.

5.2 Safety by infra-red.

Your door must be fitted with one of these two safety systems:

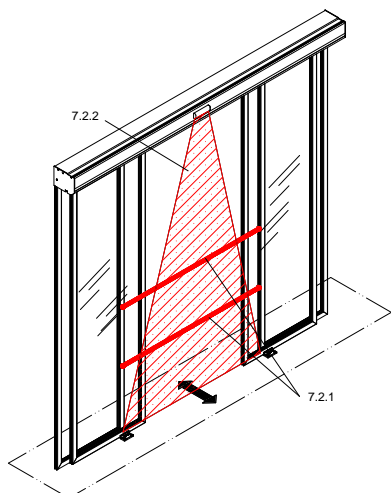

5.2.1 Photocell system with detection curtain to prevent this closing, avoiding any possible trapping.



This element must be free of any obstacles which interrupt the beam, and must be perfectly clean.

5.2.2 Presence sensor. The presence of any object in the detection area activates the photocell, stopping the door from closing and thus preventing any trapping.



Elements which may affect this presence area, such as plants, rugs, etc., should be avoided.

5.3 Safety in the event of power failure

ERREKA operators are fitted with a battery-operated emergency opening system in accordance with Standard UNE EN 16005, which, in the event of power failure, moves the door to open position with the motor released.

This system is clearly indicated on the digital switch display by the icon in the central part of the status bar.

A damaged or flat backup battery is indicated on the display by warning codes 21 and/or 22.

Warn the technical service urgently if the display indicates a flat battery.

The operator has other battery-operation modes that allow work to continue normally in the absence of mains power or for the operator to work without batteries. These modes do not comply with Standard UNE EN 16005, this being clearly indicated by the and icons on the digital selector display and in the middle of the status bar if activated. In the event that the is displayed, the operator is working in accordance with the UNE EN 16005 standard.



Current regulations REQUIRE the operation of this system; regular checks are compulsory in order to prevent accidents in the event of emergency. If this system does not work correctly, there is a possibility of becoming trapped in the site in the event of an emergency.

6. EXTERIOR KEY (Opening pulse/Closing pulse)

The exterior key allows the door to be opened and closed from outside.

	Mode	Function	Description
		Closing pulse	Every time the closing pulse is activated, the door closes and stays in this position. The door will remain closed even when the power supply fails.
		Opening pulse	The door carries out an opening and closing cycle every time the pulse is activated. After the cycle, it switches to the mode indicated in the digital or rotary selector.

7. DOORS WITH ANTI-PANIC FITTING (Optional)

The Anti-panic fitting allows the door to be opened completely, in evacuation direction, by mechanical operation (pushing). There is therefore a maximum sized gap for exit in the event of emergency.

The closing bolts on the moving leaves can be used to override the anti-panic system, allowing the door to be locked when the site is closed.

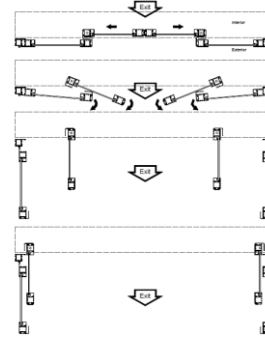

The bolt must be in up position so the door can be opened in the event of emergency.

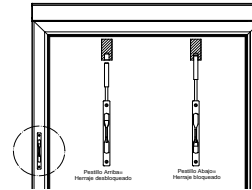

8. DOORS WITH ELASTIC KIT - C048 (Optional)

The ELASTIC KIT allows the door to open automatically using an elastic rubber band when the emergency signal is activated. The motor stops working against the door, which opens thanks to the action of the elastic band. If the tensioning force of the elastic band is not suitable, the display will show warning code 33. In this case, alert the technical service urgently.

9. USER PARAMETERS CONFIGURATION

The digital selector can be used to configure some basic parameters using the digital selector.

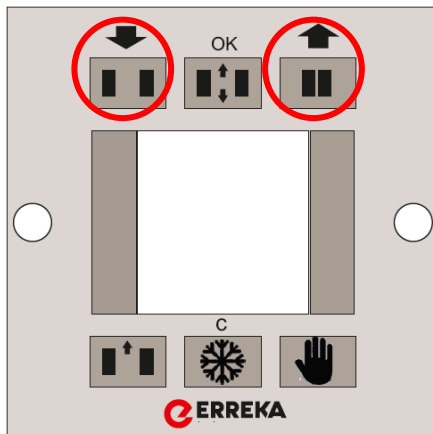

Accessed by pressing the 2 keys at the same time for 3 seconds:

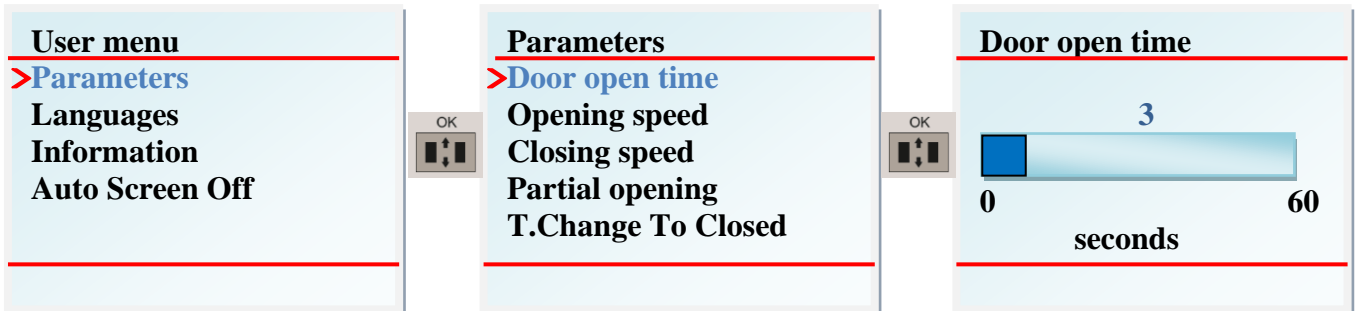

The selector screen will show the following menu:





To accept the change or move forward in the menu, press  ; to exit or to move back in the menu, press 

These are the parameters which can be configured from the **User Menu**:

1.1 Parameters		
	1.1.1 Door open time	<i>Adjustable time (0 to 60 sec)</i>
	1.1.2 Opening speed	<i>Adjustable speed (+/- 10% technician value)</i>
	1.1.3 Closing speed	<i>Adjustable speed (+/- 10 % technician value)</i>
	1.1.4 Partial opening	<i>Open door position in partial opening (0 to max distance)</i>
	1.1.5 T.Change To Closed	<i>Delay time to switch to Closed mode(0 to 300 sec..)</i>
1.2 Languages		
	1.2.1 Spanish	
	1.2.2 English	
	1.2.3 French	
	1.2.4 Dutch	
	1.2.5 Portuguese	
	1.2.6 Basque	
	1.2.7 Polish	
1.3 Information		
	1.3.1 General	
		1.3.1.1 Commision. date
		1.3.1.2 Operator type
		1.3.1.3 Serial number
		1.3.1.4 Last maint. date
	1.3.2 Machine	
		1.3.2.1 Number of cycles
		1.3.2.2 Funct. time
		1.3.2.3 Cycles last mainten.
		1.3.2.4 Last warning code
1.4 Auto Screen Off		
	1.4.1 Disabled	
	1.4.2 Enabled	

10. LOCATION OF FAILURES AND ACTION PROCEDURE

Code	Description	Possible cause	Possible solution
01	Setup incomplete	The initialisation operation or setup has not been completed	Activate setup operation using the digital or rotary selector
02	Encoder failure	The motor may be locked or the encoder damaged.	Check if there are any obstacles or blockages and remove them.
03	Electro-lock failure	The electro-lock may be blocked	Repair or change the electro-lock
08	Internal photocell activated	Obstacle in the photocell detection area.	Withdraw the obstacle
09	External photocell activated	Obstacle in the photocell detection area.	Withdraw the obstacle
10	Internal radar activated	Obstacle in the radar detection area	Withdraw the obstacle
11	External radar activated	Obstacle in the radar detection area	Withdraw the obstacle
12	Safety sensor 1 activated	Obstacle in the safety sensor detection area	Withdraw the obstacle
13	Safety sensor 2 activated	Obstacle in the safety sensor detection area	Withdraw the obstacle
17	Principal voltage failure (power source)	Input current anomalous or power fuse failed	Change the power fuse or stabilise the power input current
20	Anti-crush	A person or obstacle is trapped in the door.	Withdraw the obstacle
21	Battery damaged	The battery has no power	Change the battery
22	Battery flat	The battery power is below that required	Leave the battery to charge
23	Emergency (anti-fire)	The anti-fire signal is activated	Disable the anti-fire signal
24	Continuous anti-crush	A person or obstacle has become trapped in the door.	Remove the obstacle and reset.
29	Integrated anti-panic	The leaves of the anti-panic fitting are open	Interlock the leaves in their position
35	Incomplete reset	The operator cannot perform a RESET	Analyse if the door is blocked by any device or obstacle.



In the event of a warning or error, the operator will execute a self-diagnosis. In the event that the cause of the alert or error has been rectified, the operator will try to automatically restore the operation. If in these assumptions you find no solution and the operator does not automatically restore, perform a RESET.

FOR ANY OTHER FAILURE PLEASE CONTACT ERREKA

11. PROCEDURE IN THE EVENT OF POWER FAILURE

11.1 Anti-panic mode

In the case of power failure, the door opens and remains open if in "automatic" or "exit only" mode. If the door is in "Door Closed" position, this position will be maintained. The door returns to normal operation when the power is restored.

If the door is in "Door Closed" position and the power does not return, the door can be opened using the batteries with the exterior key, activating the opening pulse. Likewise, when the door is in open position without any power, it can be closed using the battery with the exterior key, activating the closing pulse.

If it does not work with the battery and there is an electro-lock locking the door, open the door manually by releasing the electro-lock using the interior and exterior manual handles.

Pull on the "manual handle" and open the door manually by separating the leaves.

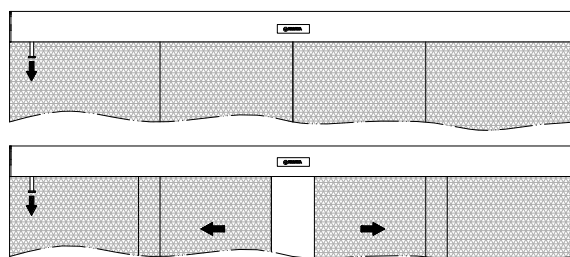

12. TECHNICAL SUPPORT

For any technical queries or help, contact our after-sales service on +34 900 926 981 or by email to service@erreka.com

*For greater durability, reliability and safety, we recommend regular checks **[[AT LEAST TWICE A YEAR]]**. ERREKA offers different types of regular maintenance which will adapt to the needs of the equipment.*

ERREKA counts on an instruction and ongoing training process for its officially approved technicians, thus guaranteeing a fully professional technical service.

13. MAINTENANCE

13.1 Maintaining the equipment.

In accordance with European standard UNE EN 16005, the owner of the door must hire an authorised company to carry out the maintenance service, thus ensuring the proper operation of the door and all safety devices.

13.2 Maintenance tasks reserved for the user.

The maintenance tasks to be carried out by the user are limited to keeping the door orderly and clean.

Do not use high-pressure water or abrasive products.

Do not expose any part of door to alkali (ammonia or similar).

Clean the glass regularly with specific glass-cleaning products which do not damage the aluminium.

Clean the rest of the door with a damp cloth and pH neutral soap.

13.3 Spare parts.

All parts must be ERREKA Connected Access originals and must be installed by ERREKA technical personnel. ERREKA shall be in no case liable for any damage which may be caused due to interventions by unauthorised personnel.

14. WARRANTY

The WARRANTY shall be 1 year as of delivery of the installation (installation delivery protocol), provided there is a maintenance contract with ERREKA Technical Service and there are no payment arrears for the installation or the maintenance contract.

15. MAINTENANCE BOOK

GENERAL INSTALLATION DETAILS	
Make:	Serial N°:
Operator:	Profiles:
<input type="checkbox"/> GLOBAL 4 <input type="checkbox"/> ERTAIN 4 <input type="checkbox"/> TELESCOPIC 4	<input type="checkbox"/> CLAMP <input type="checkbox"/> GRIPPER <input type="checkbox"/> SLIM 20 <input type="checkbox"/> ECO 32 <input type="checkbox"/> THERM 40 <input type="checkbox"/> COMPACT <input type="checkbox"/> COMPACT SLIM <input type="checkbox"/> COMPACT SENDO <input type="checkbox"/> ANTI-PANIC
CONFIGURATION: <ul style="list-style-type: none"> • SLIDING DOOR (GLOBAL 4/ERTAIN 4): <input type="checkbox"/> 2+2 <input type="checkbox"/> 2+0 <input type="checkbox"/> 1+1 <input type="checkbox"/> 1+0 • TELESCOPIC 4 SLIDING DOOR: <input type="checkbox"/> 4+2 <input type="checkbox"/> 4+0 <input type="checkbox"/> 2+1 <input type="checkbox"/> 2+0 • CURVED SLIDING DOOR: <input type="checkbox"/> 2+2 <input type="checkbox"/> 2+0 <input type="checkbox"/> 1+1 <input type="checkbox"/> 1+0 	
USE OF THE INSTALLATION: <input type="checkbox"/> PUBLIC <input type="checkbox"/> PRIVATE	EMERGENCY EXIT: <input type="checkbox"/> YES <input type="checkbox"/> NO
DATE - INSTALLATION:.....	DELIVERY DATE - INSTALLATION:.....

INSTALLER			
Company		Town	
Address			
Tel:		Fax:	

OWNER			
Company		Town	
Address			
Tel:		Fax:	

INSTALLATION CHECKLISTS

Mechanical/electrical elements	OK	No OK	Remarks
Fastening / Fall-arrest Cover			
Moving leaf fastening			
Profile/glass finish			
Limit switches			
Door parameters: speed, etc.			
Control panel			
Motor			
Functions selector			
Exterior key			
Remote control			

Safety elements	OK	No OK	Remarks
Door sensitivity (trapping)			
Photocells (barrier)			
Photocell (eyes type)			
Safety sensor			
Fire alarm			
Anti-panic system (profiles)			
Anti-panic system (batteries)			
Safety padlock/lock			
Safety rubber			
Guards			

Activation elements	OK	No OK	Remarks
Activation pushbuttons			
Infra-red sensor			
Remote control			
Microwave radars			
Pushbutton (disabled)			
Others:			

Documentation	OK	No OK	Remarks
Explanation of operation			
Delivery of user manual			
Maintenance book			
CE marking documentation			

MAINTENANCE OPERATIONS

1. CLEANING AND ADJUSTMENTS - OPERATOR	M	1	2	3
Clean state inside the operator	X			
Clean state and verification of the rolling profile	X			
Clean state and verification of the wheels	X			
Belt tautness adjustment	X			
Check of drive and return pulleys	X			
Check and adjustment of fastenings: operator, arms, flanges, side stoppers, fall arresters and cover	X			

2. ADJUSTMENTS AND VERIFICATION – WIRING CONNECTIONS	M	1	2	3
Check and adjustment of Switchboard wiring	X			
Check of state of Power Source cables	X			

3. CLEANING AND ADJUSTMENTS – LEAVES AND GUIDES	M	1	2	3
Check and adjustment of moving leaves (alignment, height, etc.)	X			
Check and adjustment of padlock/lock				
Clean state and adjustments of the guides	X			
Check and adjustment in profiles: Attachments, overlaps, joints, brushes, glass fastening, etc.	X			
Replace guides			X	

4. VERIFICATION OF SAFETY AND ACTIVATION ELEMENTS	M	1	2	3
Check and test: photocells	X			
Check and test: safety sensor	X			
Check and test: mechanical closing (electro-lock)	X			
Check and test: anti-crush	X			
Check and test: emergency signal	X			
Check and test: anti-panic system (batteries)	X			
Replace batteries			X	
Check and test: anti-panic system (anti-panic profiles)	X			
Check and test: digital selector / mechanical selector	X			
Door parameters settings: speed, braking, closing force, etc	X			
Check and test: exterior key	X			
Check and adjustment: activation radars or sensors	X			
Check and adjustment: peripherals (buttons, card devices, etc.)	X			

M: Every time maintenance is carried out.

CHANGES IN THE INSTALLATION

Date: / / Technician (code):
Description:
.....
.....
..... Signature

Date: / / Technician (code):
Description:
.....
.....
..... Signature

Date: / / Technician (code):
Description:
.....
.....
..... Signature

Date: / / Technician (code):
Description:
.....
.....
..... Signature

Date: / / Technician (code):
Description:
.....
.....
..... Signature

MAINTENANCE REVISIONS

Date: / /	Technician (code):
Signed ERREKA	Signed Customer

Date: / /	Technician (code):
Signed ERREKA	Signed Customer

Date: / /	Technician (code):
Signed ERREKA	Signed Customer

Date: / /	Technician (code):
Signed ERREKA	Signed Customer

Date: / /	Technician (code):
Signed ERREKA	Signed Customer

Date: / /	Technician (code):
Signed ERREKA	Signed Customer

Date: / /	Technician (code):
Signed ERREKA	Signed Customer

Date: / /	Technician (code):
Signed ERREKA	Signed Customer

Date: / /	Technician (code):
Signed ERREKA	Signed Customer

Date: / /	Technician (code):
Signed ERREKA	Signed Customer

MAINTENANCE REVISIONS

Date: / /	Technician (code):
Signed ERREKA	Signed Customer

Date: / /	Technician (code):
Signed ERREKA	Signed Customer

Date: / /	Technician (code):
Signed ERREKA	Signed Customer

Date: / /	Technician (code):
Signed ERREKA	Signed Customer

Date: / /	Technician (code):
Signed ERREKA	Signed Customer

Date: / /	Technician (code):
Signed ERREKA	Signed Customer

Date: / /	Technician (code):
Signed ERREKA	Signed Customer

Date: / /	Technician (code):
Signed ERREKA	Signed Customer

Date: / /	Technician (code):
Signed ERREKA	Signed Customer

Date: / /	Technician (code):
Signed ERREKA	Signed Customer

MAINTENANCE REVISIONS

Date: / /	Technician (code):
Signed ERREKA	Signed Customer

Date: / /	Technician (code):
Signed ERREKA	Signed Customer

Date: / /	Technician (code):
Signed ERREKA	Signed Customer

Date: / /	Technician (code):
Signed ERREKA	Signed Customer

Date: / /	Technician (code):
Signed ERREKA	Signed Customer

Date: / /	Technician (code):
Signed ERREKA	Signed Customer

Date: / /	Technician (code):
Signed ERREKA	Signed Customer

Date: / /	Technician (code):
Signed ERREKA	Signed Customer

Date: / /	Technician (code):
Signed ERREKA	Signed Customer

Date: / /	Technician (code):
Signed ERREKA	Signed Customer

MAINTENANCE REVISIONS

Date: / /	Technician (code):
Signed ERREKA	Signed Customer

Date: / /	Technician (code):
Signed ERREKA	Signed Customer

Date: / /	Technician (code):
Signed ERREKA	Signed Customer

Date: / /	Technician (code):
Signed ERREKA	Signed Customer

Date: / /	Technician (code):
Signed ERREKA	Signed Customer

Date: / /	Technician (code):
Signed ERREKA	Signed Customer

Date: / /	Technician (code):
Signed ERREKA	Signed Customer

Date: / /	Technician (code):
Signed ERREKA	Signed Customer

Date: / /	Technician (code):
Signed ERREKA	Signed Customer

Date: / /	Technician (code):
Signed ERREKA	Signed Customer

TECHNICAL SUPPORT

+34 900 926 981

service@erreka.com

www.erreka.com